

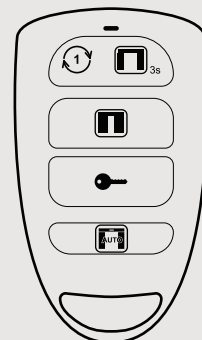

ST125

# Installation Manual

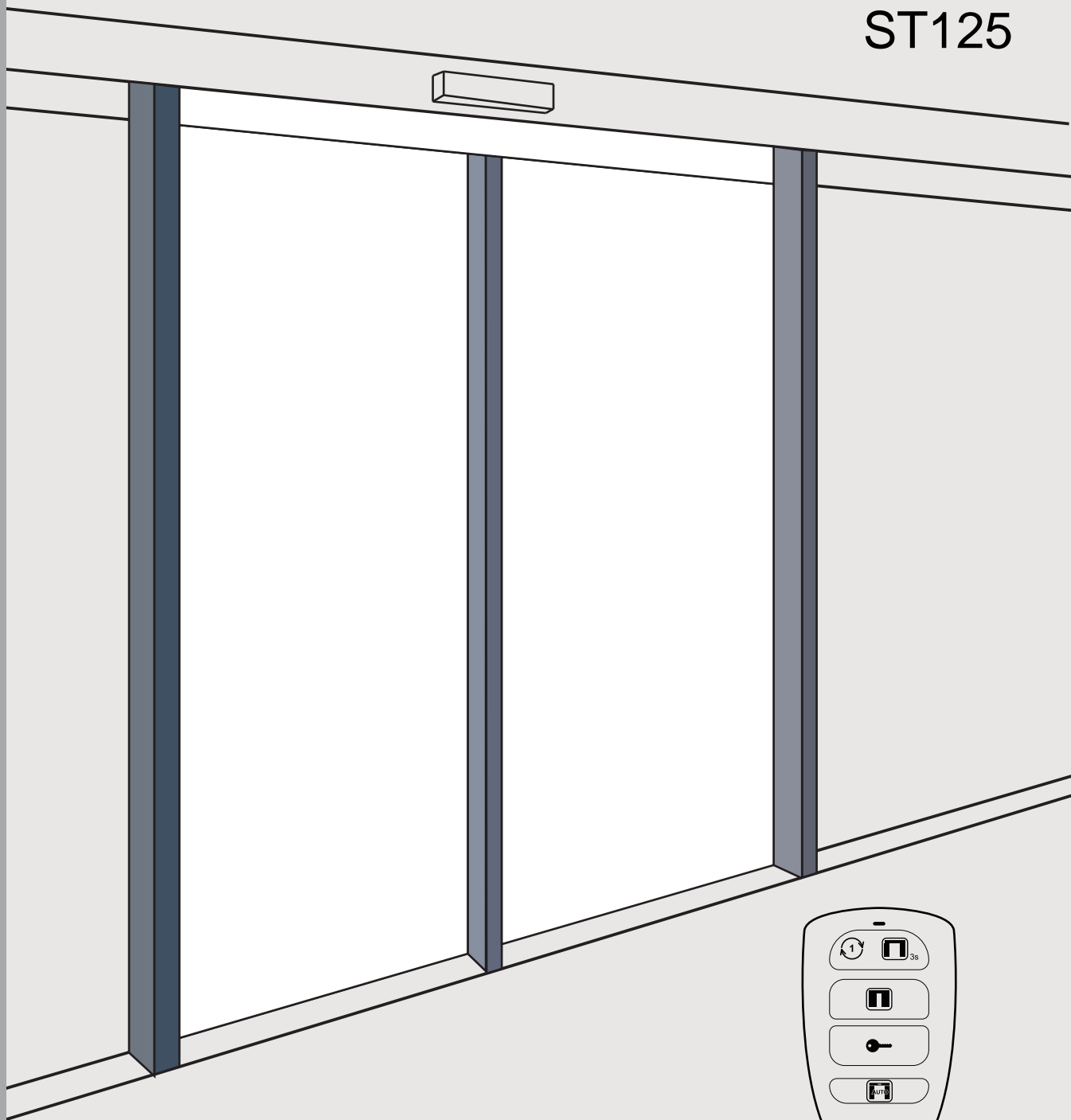

ROLLING CODE



- Installation of automatic door should be entrusted to the appointed distributor or professional installation personnel, or it may be dangerous.
  - Installation must be performed by professional installation personnel according to local law.
  - This manual must be kept well for maintenance.
-

# Contents

|                                                         |       |
|---------------------------------------------------------|-------|
| Safety Precautions .....                                | 1-2   |
| Components of mechanism .....                           | 3     |
| Sectional view of track and cover .....                 | 4     |
| Installation process .....                              | 5     |
| Product features and technical specifications .....     | 6     |
| Components List .....                                   | 7     |
| Track's cutting and installation .....                  | 8     |
| Installation of motor,controller and idler pulley ..... | 9     |
| Installation of stopper .....                           | 10    |
| Installation of hanger .....                            | 10-11 |
| Installation and adjustment of door leaves .....        | 12    |
| Belt installation of single opening .....               | 13    |
| Belt installation of double opening .....               | 14-15 |
| Belt length table .....                                 | 15    |
| Adjustment of idler pulley .....                        | 16    |
| Installation of door leaf guider .....                  | 16    |
| Installation of electronic lock .....                   | 17    |
| Installation of sensor .....                            | 17    |
| Connection of motor, controller and power switch .....  | 18    |
| Terminal details of controller .....                    | 19    |
| Connection of sensor .....                              | 19    |
| Connection of access keypad .....                       | 20    |
| Connection of inter-lock .....                          | 21    |
| Connection of photocell .....                           | 21    |
| Connection of UPS and electronic lock .....             | 22    |
| Connection of function remote(Rolling code) .....       | 22-24 |
| Adjustment of open and close paramenters .....          | 24-25 |
| Trouble shooting .....                                  | 26-27 |

# Safety Precautions

- The contents and categories a user must abide by are presented and described by the following graphic expressions.



## Warning

Misoperation may cause injury even death to the operator.



## Caution

Misoperation may cause injury or physical loss to the operator.



This stands for the contents prohibited.



This stands for compulsory contents.



## Warning

- ❗ Installation and adjustment must be carried out according to the Installation Manual. Carelessness in installation and adjustment will lead to such accidents as fire, electric shocks or fall off.
- ❗ During the installation never allow the pedestrians to pass through the automatic door or approach the work site. Because any tools or parts falling off during the installation will cause injury to the pedestrians.
- ⊘ Never remodel the parts, otherwise fire, electric shocks or fall will occur.
- ⊘ Never use the power beyond the stipulated voltage or frequency, otherwise fire or electric shocks will occur.
- ❗ The sensor should be set and adjusted to make sure that the opening area of the door will fully fall into the range of sensor detection without any blind area. If the detecting range is too small or having blind area, the pedestrians will be collided or squeezed by the door, causing injury.
- ❗ Do fix up photocell to ensure the detecting range for the walking area of the door leaf, otherwise the pedestrians will be collided or squeezed by the door leaf, causing injury.

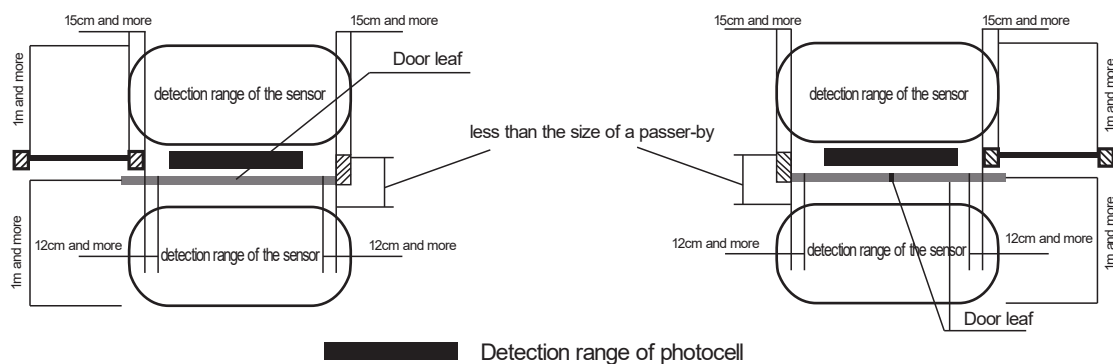



## Caution

- ⊘ Never use the door in a place subject to dampness, vibration or corrosive gas, otherwise it will cause such accidents as fire, electric shocks or fall.
- ⊘ Make sure that a space of over 30mm should be available when the door is opened, otherwise your fingers may be squeezed by the door leaf and upright column, causing injury.
- ⊘ Never cut off power when the door is in operation, otherwise it will cause injury of the pedestrians.
- ⚠ Please use sticker on door leaves. If not, it will cause injury to the passer-by who has lost sight of the door leaf.
- ⊘ Never install an electric device with a capacity of >DC24V 300mA to the controller, otherwise it will cause fire.

## Other precautions

- Never use a door leaf that exceeds the specified weight, otherwise it will cause failure.
- For selection of batteries
  - Please use them after charging for 24 hours.
  - The service life of batteries lasts for 3-5 years at an ambient temperature of 0℃-40℃. Excessive temperature will shorten the service life of batteries.
  - If after charging 24 hours the battery still doesn't work, it shows the service life has expired. Replace it immediately.
  - Check batteries each half year.
- For selection of electronic lock
  - Never use it in an environment excess an ambient temperature of 0℃-40℃, otherwise it will cause malfunction.
- Using our brand electronic lock, and special installing brackets. If not using our lock, please make sure the quality of lock, or the bad electronic lock will damage.

# Components of mechanism

- Name of components

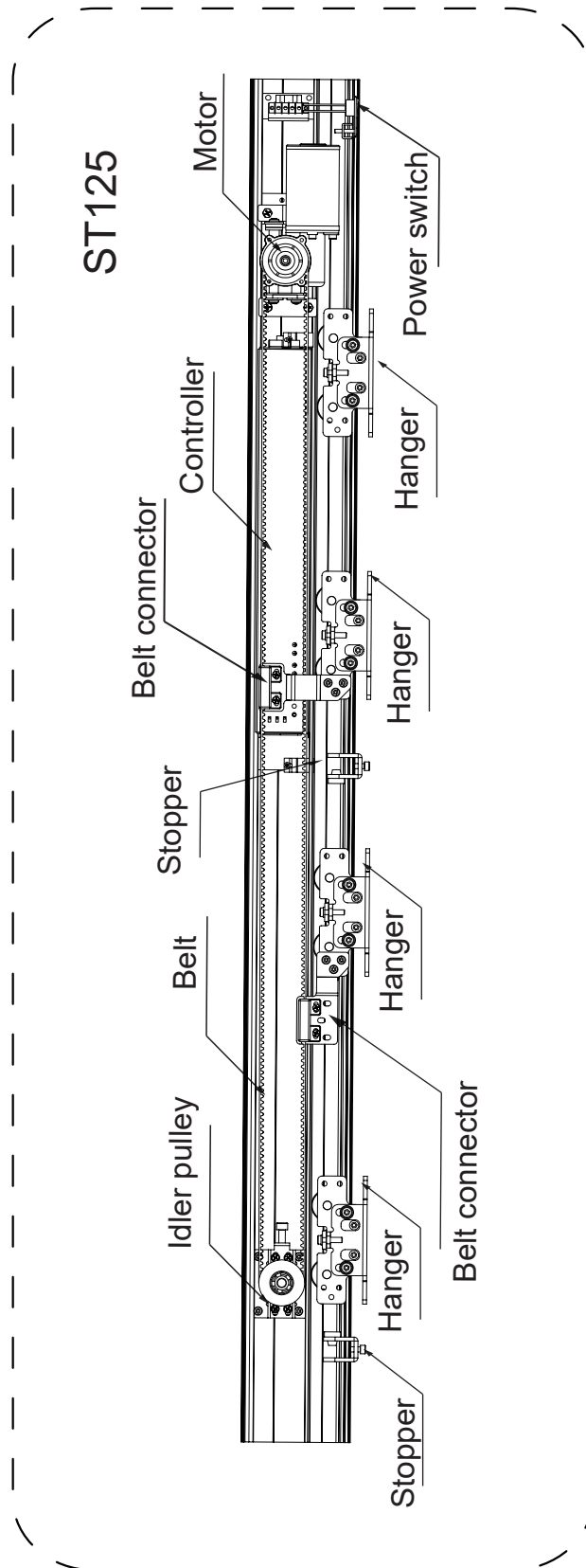

## Sectional view of track and cover

- Sectional view  
Caution: This view is not in a scale of 1:1.

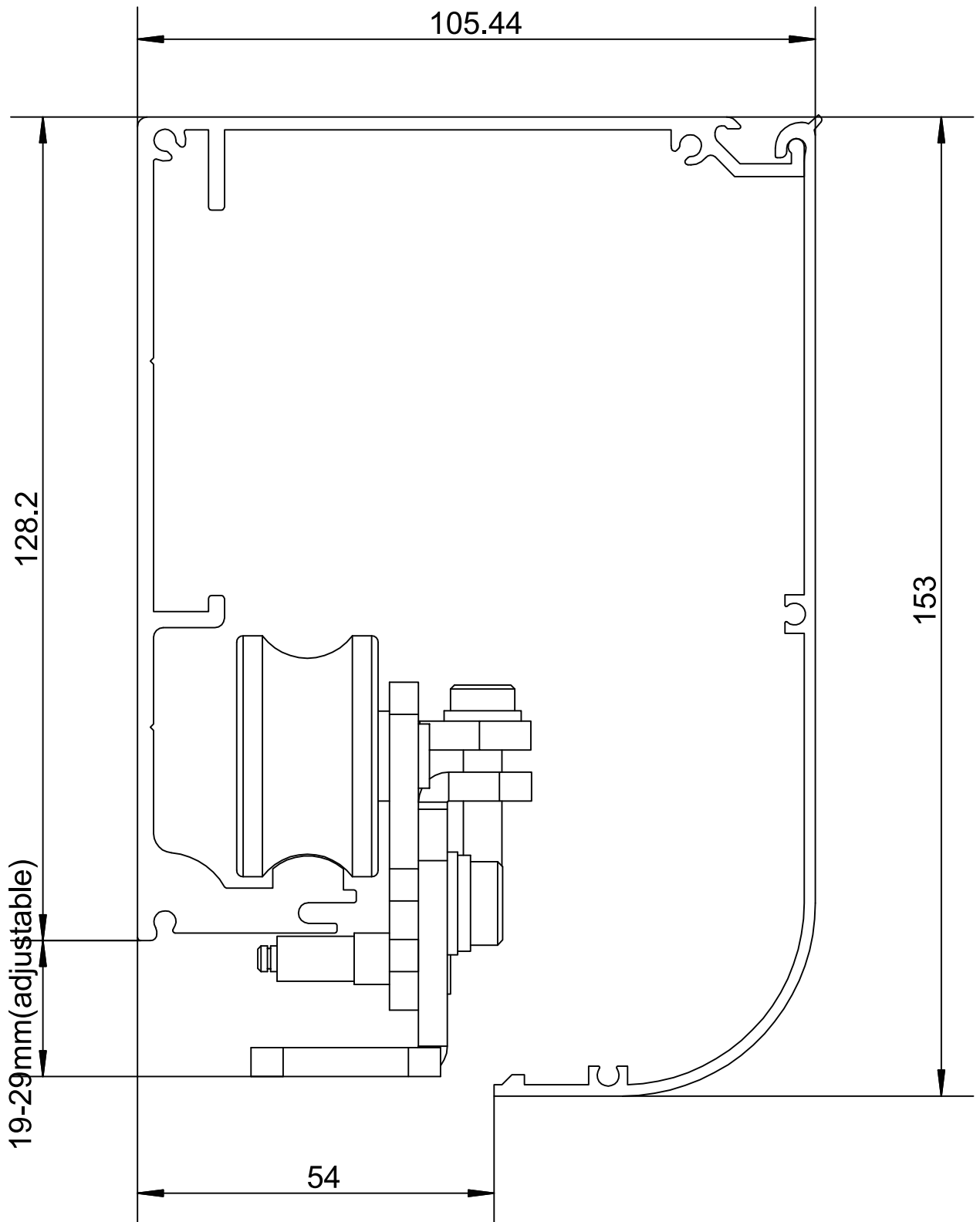

# Installation process

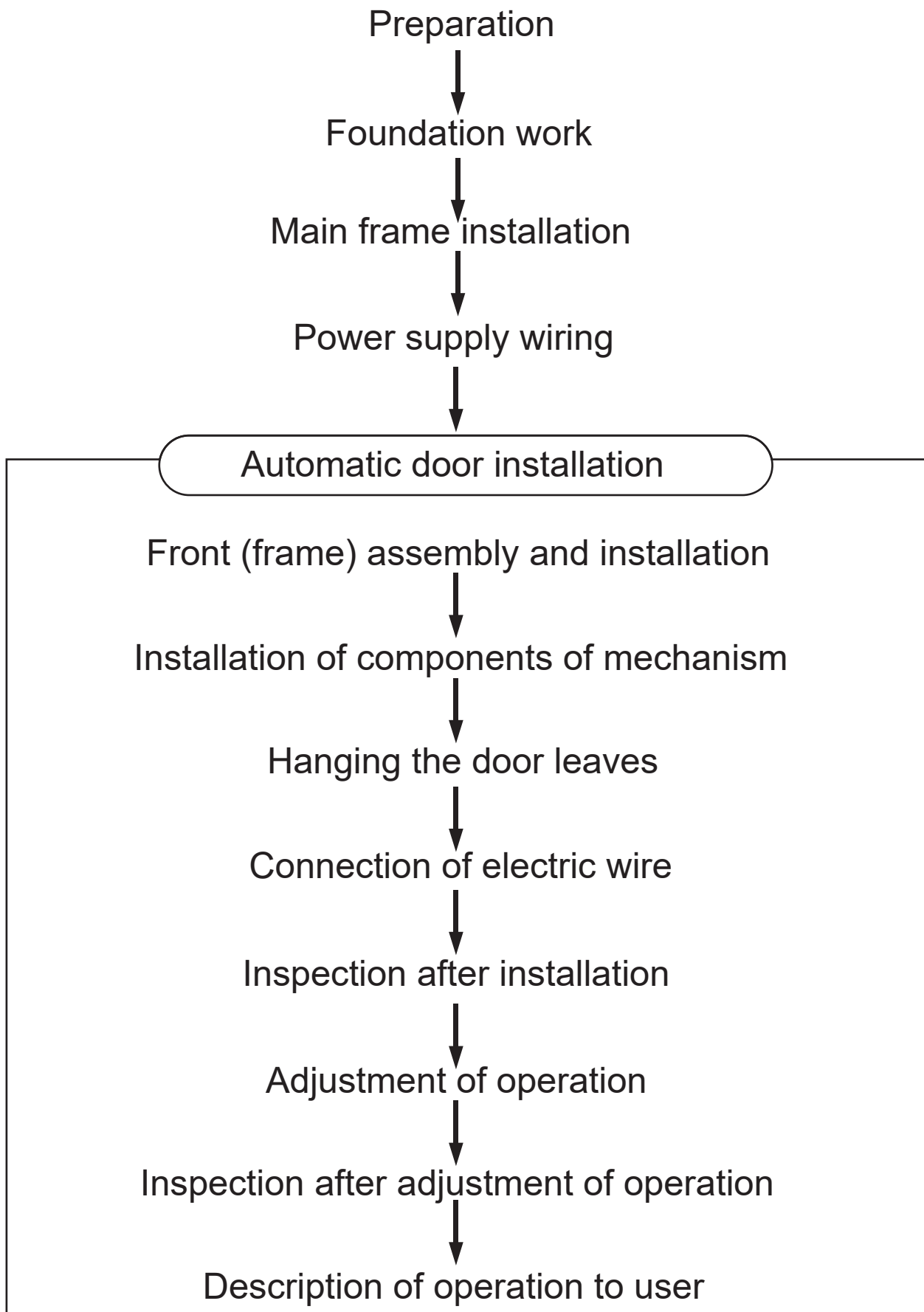







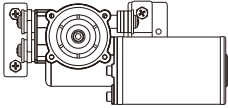

## Product features

- Microprocessor control technology and advanced mechanical manufacture.
- Self-learning when power on, this function is selectable by user.
- Digital screen, easy and exact to adjust working data.
- Brushless DC motor, long working life and low noise ( less then 40dp).
- Anti-clamp when close and open.
- Function terminals for electronic lock, access keypad, function keypad, function remote and so on.
- Special terminals for anti-clamp side sensor, more safety.
- Square motor for narrow door entrance (ST125).

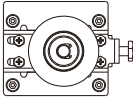
## Technical specifications

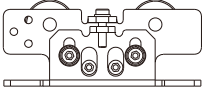
| Specifications        | ST125                   |                |
|-----------------------|-------------------------|----------------|
| Door leaf mode        | Single-opening          | Double-opening |
| Door leaf weight      | Max 150kg               | Max 2*140kg    |
| Door leaf width       | DW=700-1300mm           | DW=600-1250mm  |
| Voltage               | AC 90-250V 50-60Hz      |                |
| Opening speed         | 10-50cm/s (Adjustable)  |                |
| Closing speed         | 10-50cm/s (Adjustable)  |                |
| Opening time          | 0-20second (Adjustable) |                |
| Manual open force     | <40N                    | <50N           |
| Motor                 | 24V 55W 2300rpm         |                |
| Operating temperature | -10 C ~ +70 C           |                |

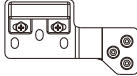
# Components List

| Description         | Schematic diagram                                                                   | Quantity        |                 |
|---------------------|-------------------------------------------------------------------------------------|-----------------|-----------------|
|                     |                                                                                     | Single-leaf     | Double-leaves   |
| Motor (ST125)       |    | 1               | 1               |
| Controller          |    | 1               | 1               |
| Idler pulley        |    | 1               | 1               |
| Power switch        |    | 1               | 1               |
| Hanger              |   | 2               | 4               |
| Belt connector(A)   |  | 1               | 1               |
| Belt connector(B)   |  | 1               | 1               |
| Stopper             |  | 2(left & right) | 2(left & right) |
| Toothed Belt        |  | 1               | 1               |
| Fastenings          |                                                                                     | 1 set           | 1 set           |
| Installation Manual |                                                                                     | 1 set           | 1 set           |

# Track's cutting and installation

## ● Cutting

Standard length of track: 4200mm.

Over-length track can be customized.

$$L = W - 10\text{mm}$$

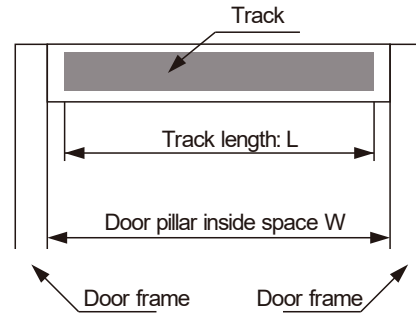

## ● Installation

The track is installed at a height of  $DH+23\text{mm}$  from the ground (based on the bottom of the track).

(1) Drill holes in aluminum track.

(2) Fix one end of aluminum track, check the level by gradienter, then fix another end of track.

(3) Fix the aluminum track to steel structure firmly.

1. Frame door

2. Frameless door

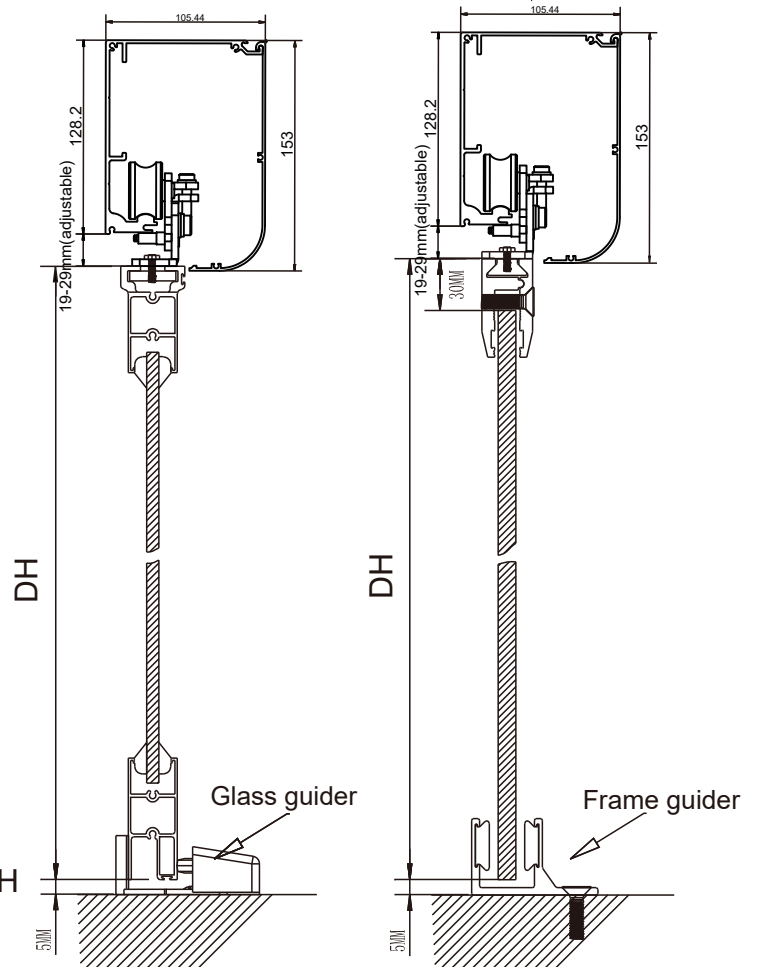

### Caution

(1) The track must be level.

(2) The height of movable door leaf is  $DH$

(3) The clearance height over the track should be more than 50mm.

## Installation of motor

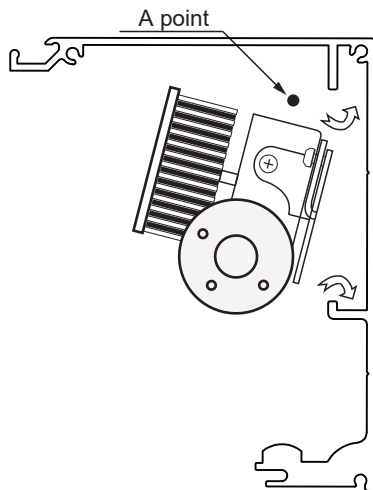

1. The lead wire with a connector is put before the motor.
2. The mounting part is inserted into the upper groove of the track properly.
3. Then it is inserted into the lower groove.
4. The motor is moved to the right end of the track.
5. Tighten the mounting bolts.
6. The lead wire with a connector passes through the upper part of the motor as A and goes beyond the left side. See to it that the lead wire should never be dragged.

Caution: Misoperation in step 2、3 and 5 will result in falling off.

## Installation of controller

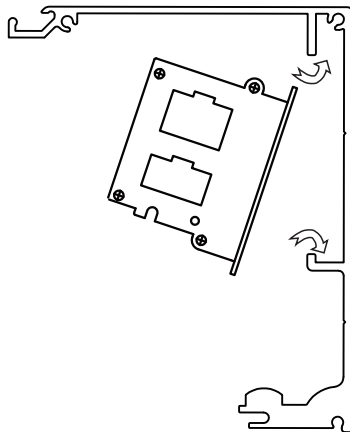

1. The controller is firmly inserted into the upper groove.
2. It is firmly inserted into the lower groove.
3. The motor and flexible wire of the terminal blocks are moved to the connecting position.
4. The mounting bolts are tightened.

Caution: Misoperation in step 1 and 2 will result in falling off.

## Installation of idler pulley

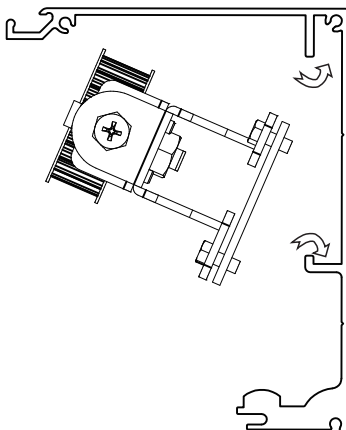

1. The mounting part of the idler pulley is firmly inserted into the upper groove of the track.
2. It is firmly inserted into the lower groove.
3. The idler pulley is fixed temporarily with a fixing bolt so that it can be moved slightly.

Caution: Misoperation in step 1 and 2 will result in falling off.

## Installation of stopper

1. Loosen the mounting screw of the stopper.
2. Find out the open and close position, and confirm the stoppers' position.
3. The mounting bolts are tightened firmly with a socket screw wrench.

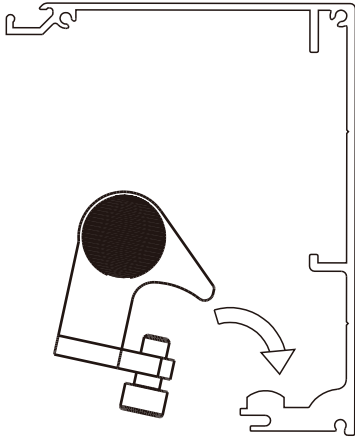

## Installation of hanger

1. Loosen nut A of the hanger and remove the anti-drop device from the hanger.
2. Install hangers to door leaves.
3. Hang door leaves on aluminium track.
4. Fix anti-drop device to hanger.

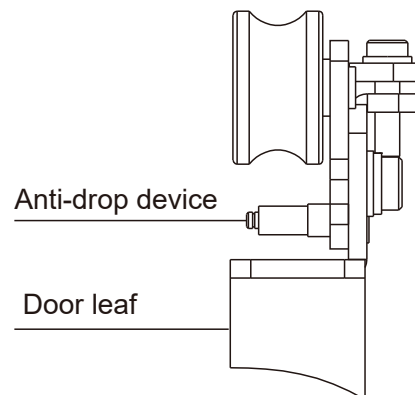
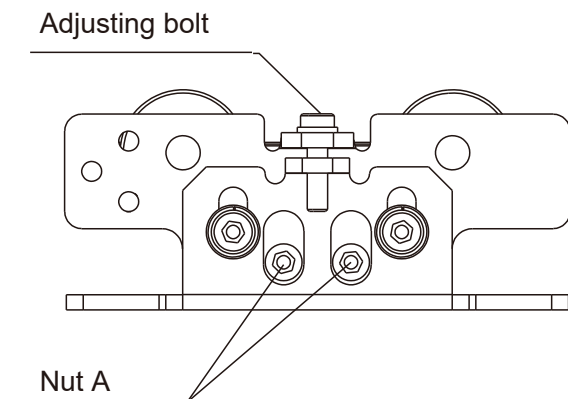

# Installation of hanger (to be continued)

## ● Hanger installation

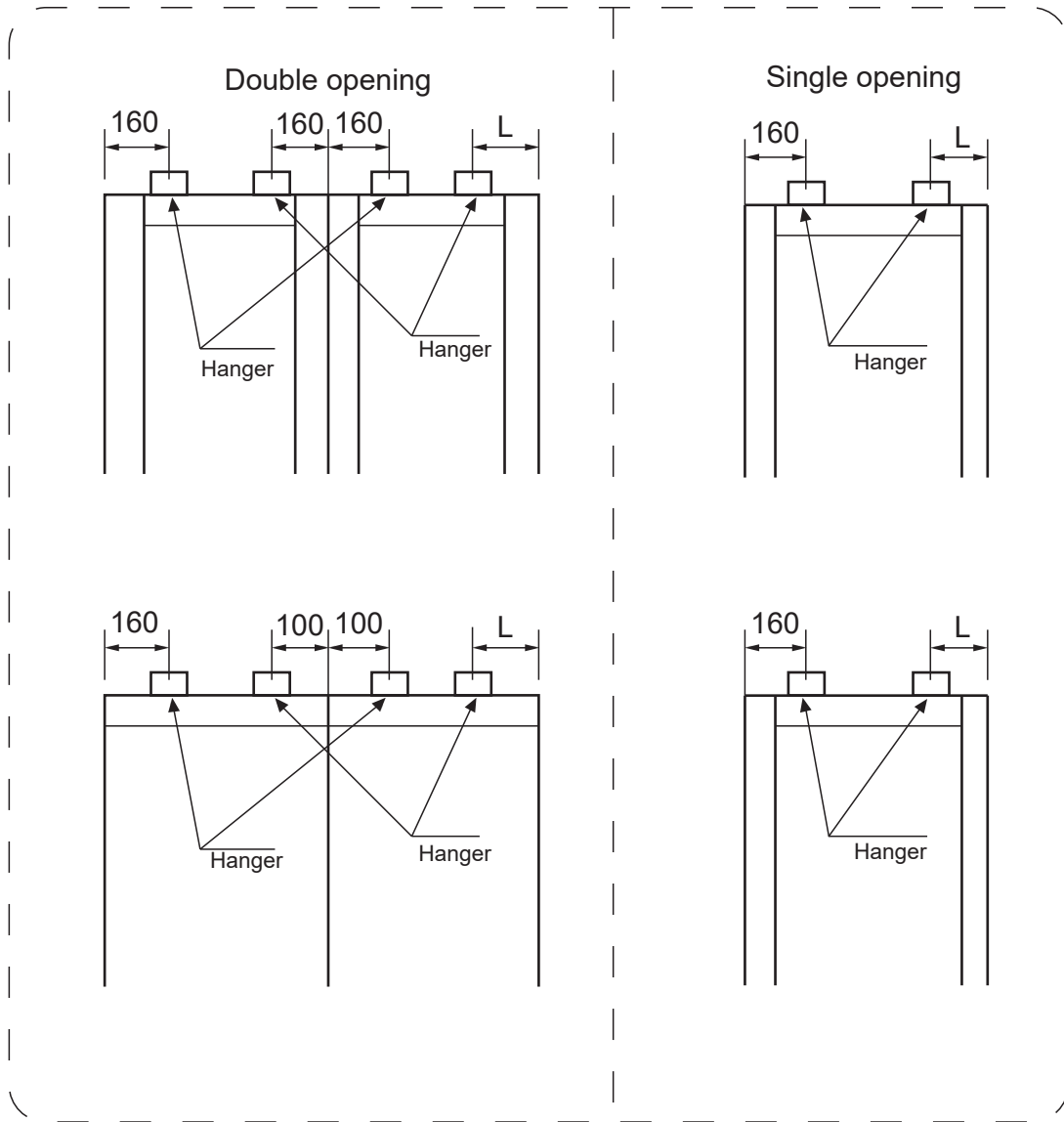

Caution: ST125

- If movable door leaf has an approximate width to the fixed leaf,  $L=300\text{mm}$ .  
If the space on the leaf can't meet the requirement of  $L=300\text{mm}$ , HH115 can be chosen.  
If the movable door leaf width is smaller than the fixed leaf's,  $L \geq 190\text{ mm}$ .

Caution: In installation the pulley center of the hanger should be in full parallel with the door leaf.

If not, the service life of the pulley will be shortened.

# Installation and adjustment of door leaf

## ● Single opening

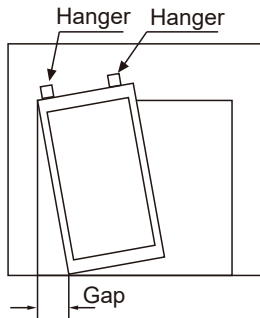

As is shown in the left figure, if the door leaf can't be installed horizontally, it can be adjusted by the adjusting bolt.

1. Loosen the fixing nut the hanger.
2. Adjust the height using the adjusting bolt.

## ● Double opening

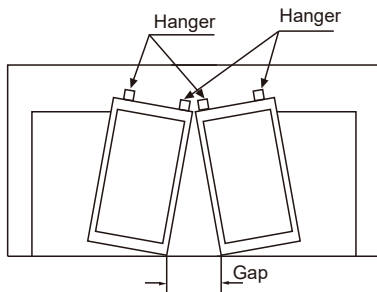

Turn clockwise , the door will ascend.  
Turn counterclockwise , the door will descend.

3. Tighten the nut that fixes the hanger.
4. Check the gap between rail and anti-drop device at 0.5mm, then fix the anchor nut.
5. Confirm the resistance during the operation.

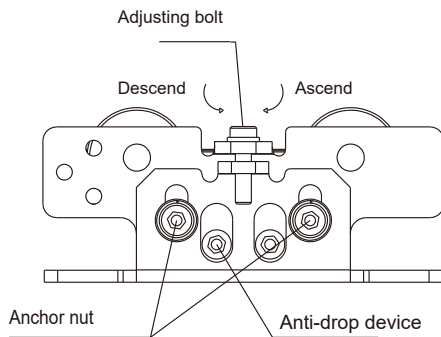

If the door leaf is hard to move, the following items should be checked to solve the problem:

1. The hanger is mounted vertically on the leaf.
2. Any friction between the floor guide and the leaf bottom of door leaf.
3. Any friction between the door leaf and frame.
4. Any friction between the hanger and anti-drop device, any friction between the hanger and the rail.

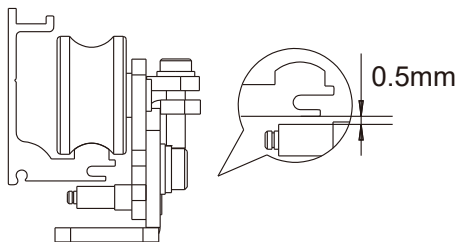

## Belt Installation of single opening

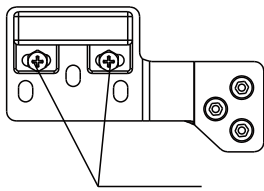

Bolt A

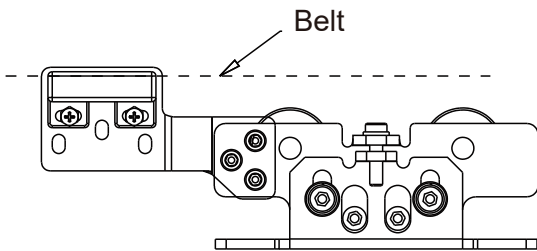
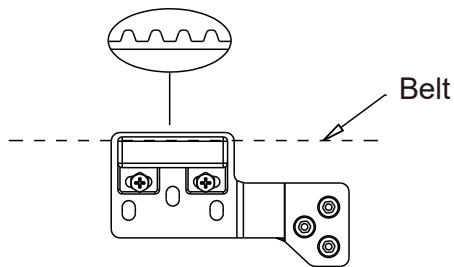

1. Remove the bolt and take off the belt fastening part from the belt connector part.

2. Cut the belt according to the belt cutting table.

Caution: Cut the belt at the center of the valley bottom.

3. Both ends of the belt are put into the fastening part from the center of the fastening part.

Caution: Never have the belt twisted in installation.

4. Fix the fastening part to the belt connector part.

Caution: the direction of the belt fastener

5. Fix the belt connector part to hanger.

Caution: Do tighten the bolts firmly.

# Belt installation of double opening

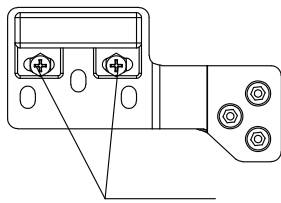

Bolt A

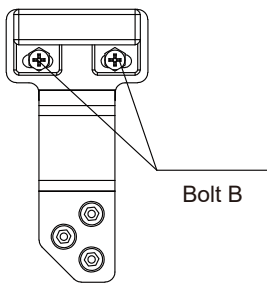
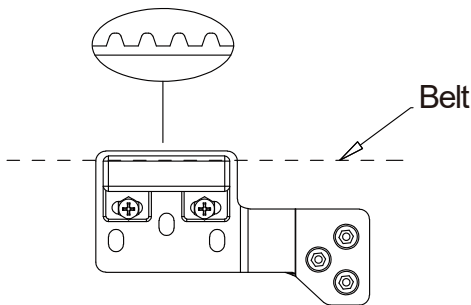

Bolt B

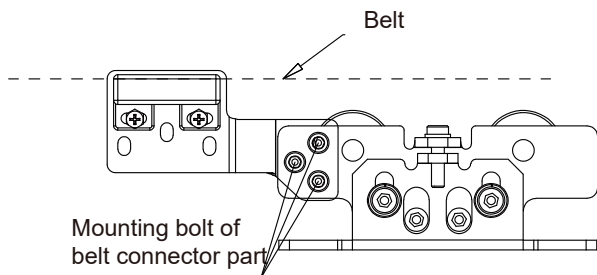
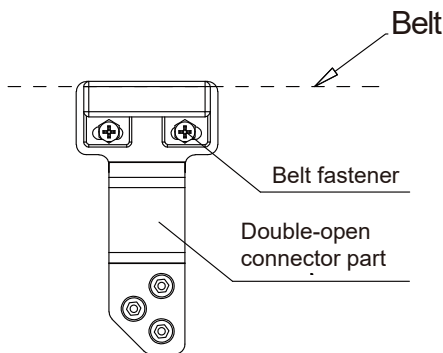

Mounting bolt of belt connector part

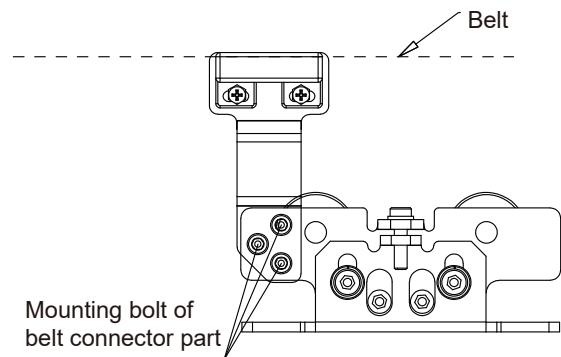

Mounting bolt of belt connector part

1. Remove the bolt and take off the belt fastening part from the belt connector part.
2. Cut the belt according to the belt cutting table.  
Caution: Cut the belt at the center of the valley bottom.
3. Both ends of the belt are put into the fastening part from the center of the fastening part.  
Caution: Never have the belt twisted in installation.
4. Fix the fastening part to the belt connector part.  
Caution: the direction of the belt fastener
5. Fix the belt connector part to hanger.  
Caution: Do tighten the bolts firmly.
6. Adjust the tension of belt refer to adjustment.
7. Keeping the two leaves closing.
- 8 Remove bolt B from the belt fastener and take it out from the belt fastening part.
9. Install the belt fastener into the belt and tighten it then.
10. Fix the belt fastener with bolts.
11. Tighten Bolt B after adjusting the door position.  
Notice: Do tighten the bolts.

## Installation position of belt fastener (belt of double-leaves)

- Exemplified by ST125:

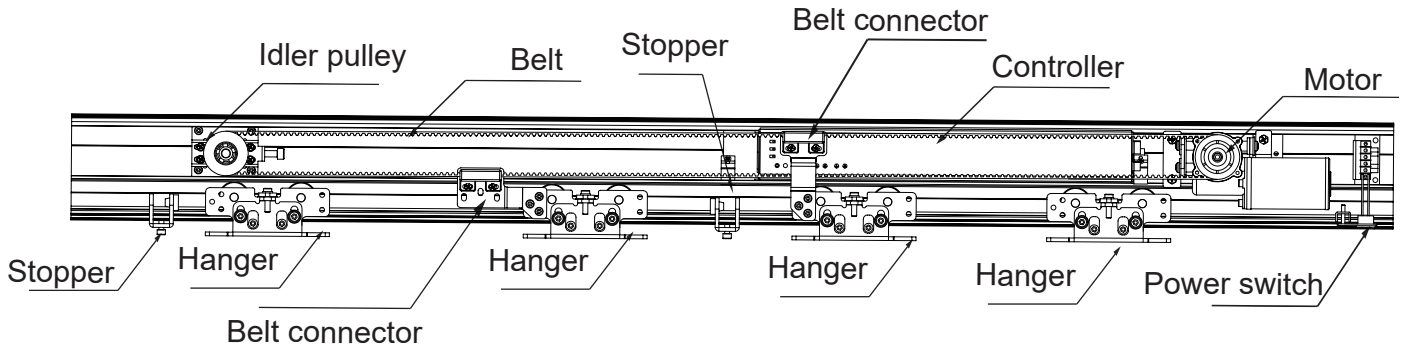

## Belt Length table

- Zoom table for minimum belt length (for reference only)

| Door width | Belt length |
|------------|-------------|
| 650        | 4100-4200   |
| 700        | 4400-4500   |
| 750        | 4700-4800   |
| 800        | 5000-5100   |
| 850        | 5300-5400   |
| 900        | 5600-5700   |
| 950        | 5900-6000   |
| 1000       | 6200-6300   |
| 1050       | 6640        |

## Adjustment of idler pulley

1. Loosen the four fastening bolts.
2. Turn the tension adjusting bolt counter clockwise to make sure the fastening bolt at the max left position.
3. Pull the idler pulley to the left to keep the belt tightened and fasten the four pressure plate bolts.
4. Turn the tension adjusting bolt clockwise so that the tension plate will be moved to the left and the belt tension increased gradually.
5. Adjusting the belt tension to tighten belt suitably.

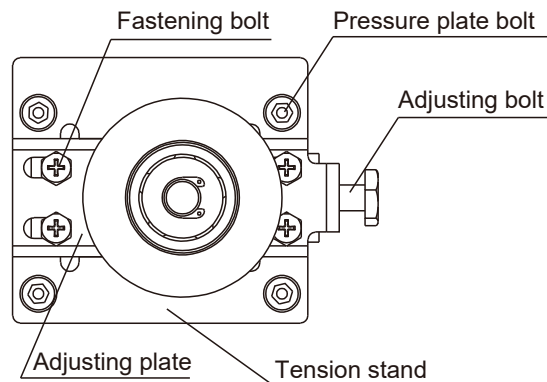

After using for some time the belt will be stretched slightly and then the belt tension should be readjusted by repeating Steps 1-5.

## Installation of door leaf guider

- Two types of door leaf guider:

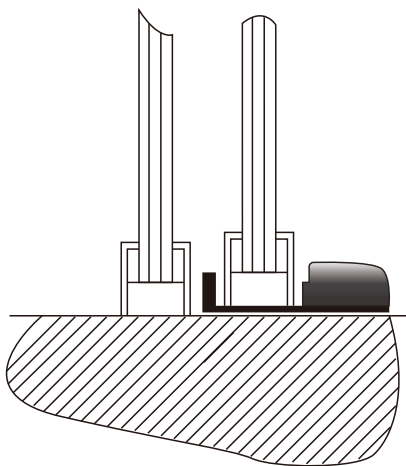

Suitable for framed door

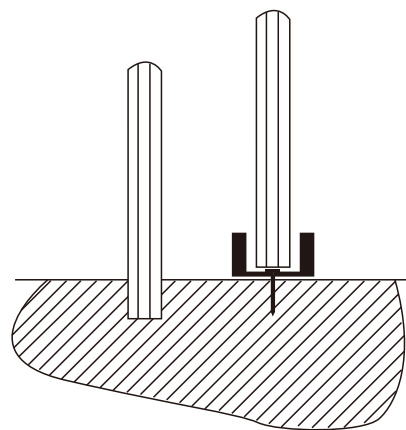

Suitable for frameless door

## Installation of electronic lock

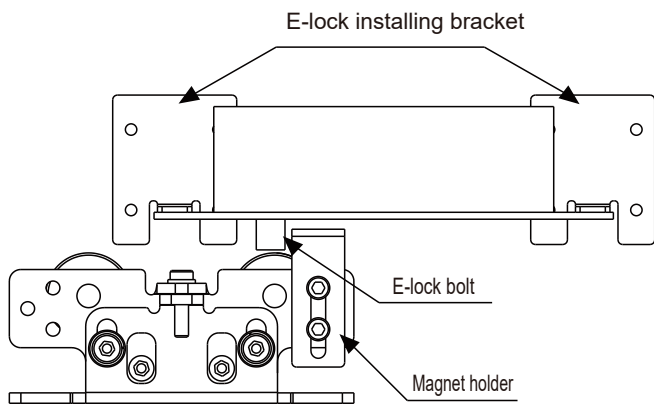

1. Connect the electronic lock with the E-lock installing bracket.
2. Inset the E-lock installing bracket to the rail.
3. Connect the magnet holder with the hanger.
4. Adjust the position of the electronic lock to make the distance between E-lock and magnet holder max 5mm, then tighten the bolt.

Caution: the position of hanger is the position when door closed.

## Installation of sensor

The sensor should be installed at the center of the door leaf.  
The max installing height of sensor is 3m.

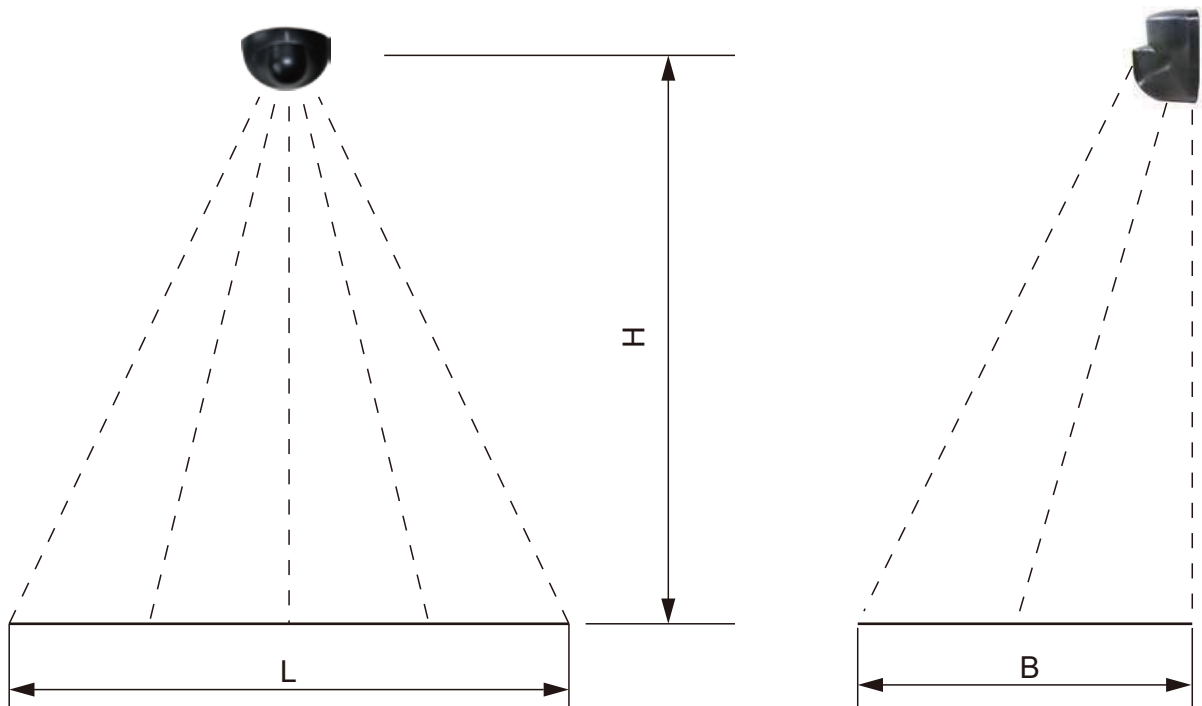

Caution: Please use our brand sensor. If not, please choose good quality sensor.

# Connection of motor, controller and power switch

Caution: All the connection should be finished under the power off status.

ST125

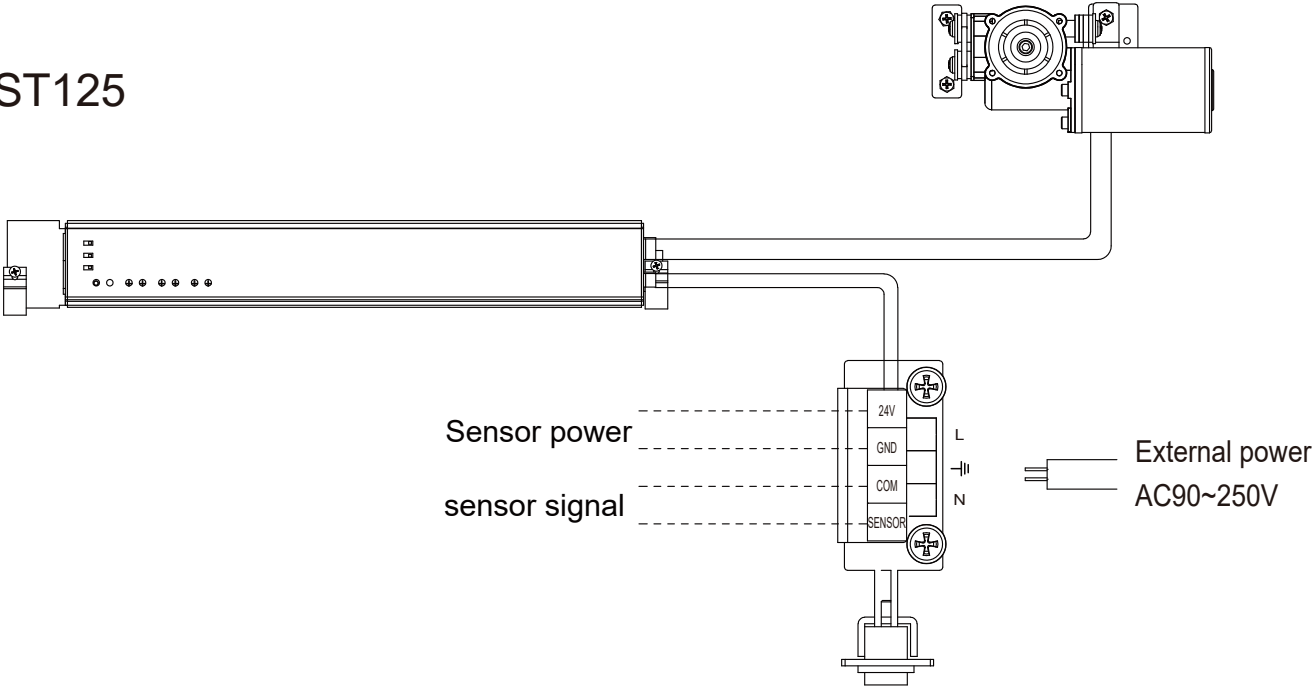

## Terminal details of controller

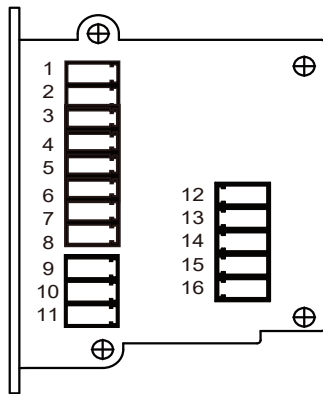
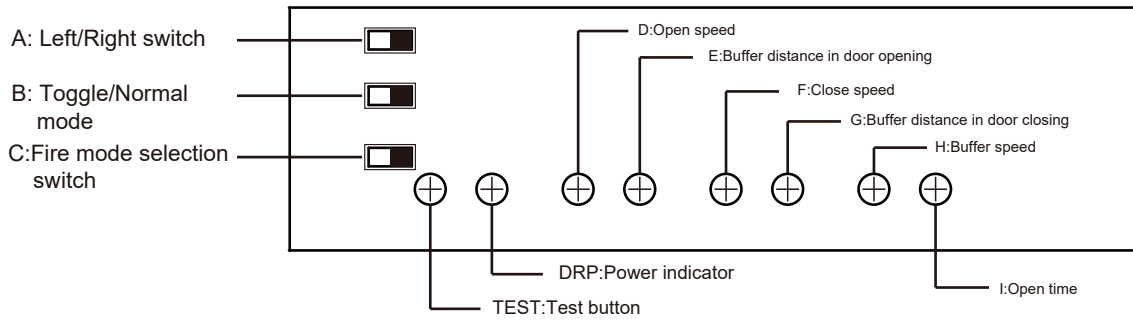

1. Photocell input
2. Access keypad
3. Interlock input
4. COM (photocell, access keypad, etc.)
5. Interlock output
6. Interlock COM
7. GND
8. +12V
9. GND
10. +24V ( UPS input)
11. Lock control (+12V)
- 12-16. Remote control receiver terminal

## Connection of sensor

**Caution:** All the connection should be conducted under the power off status.

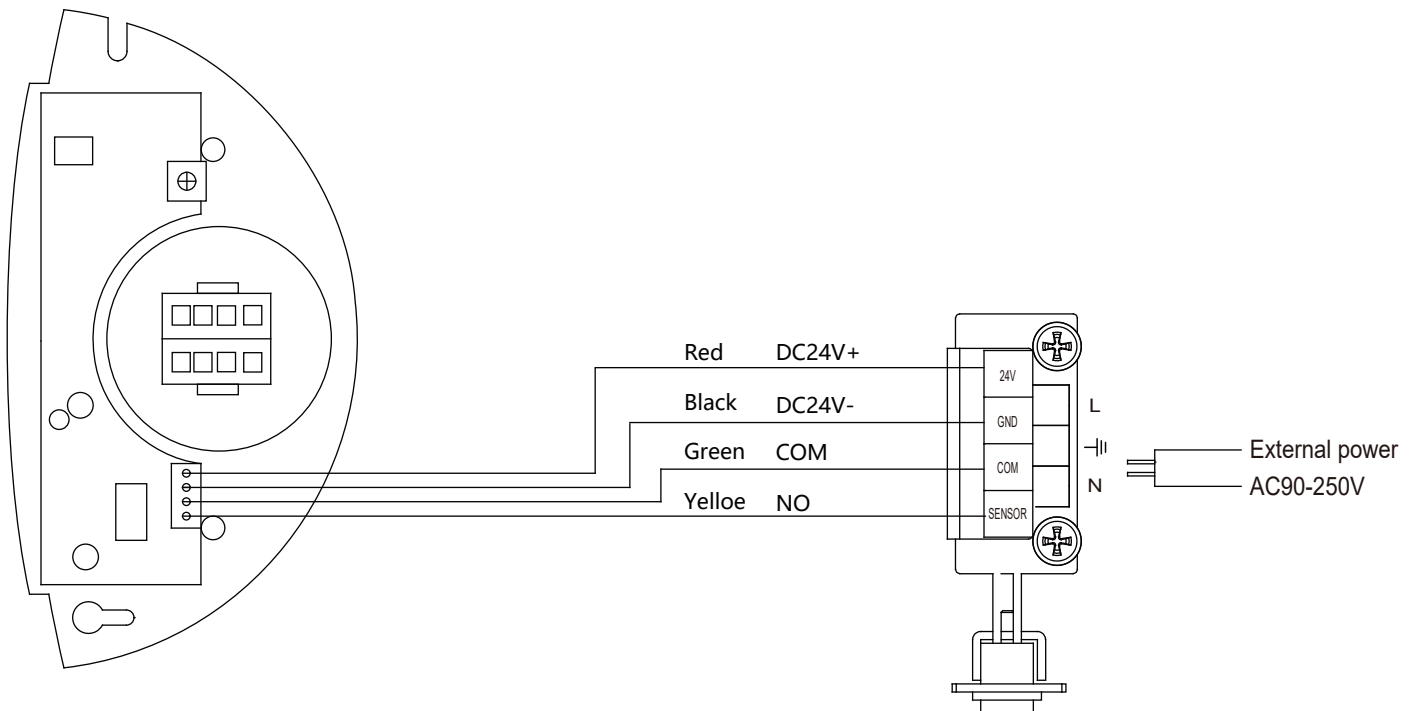

# Connection of access keypad

Caution: All the connection should be conducted under the power off status.

When connect the access keypad should pay attention of positive and negative poles.  
If the rate of work for access keypad is more than 2.4W, it needs the external power of 12V DC power.

## ● ACCESS KEYPAD

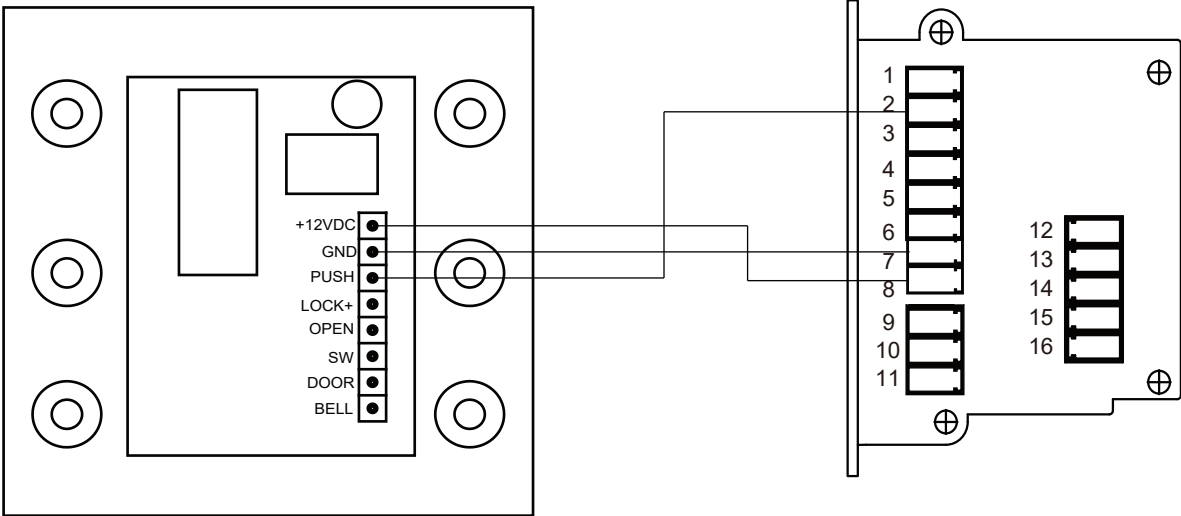

## ● ACCESS KEYPAD

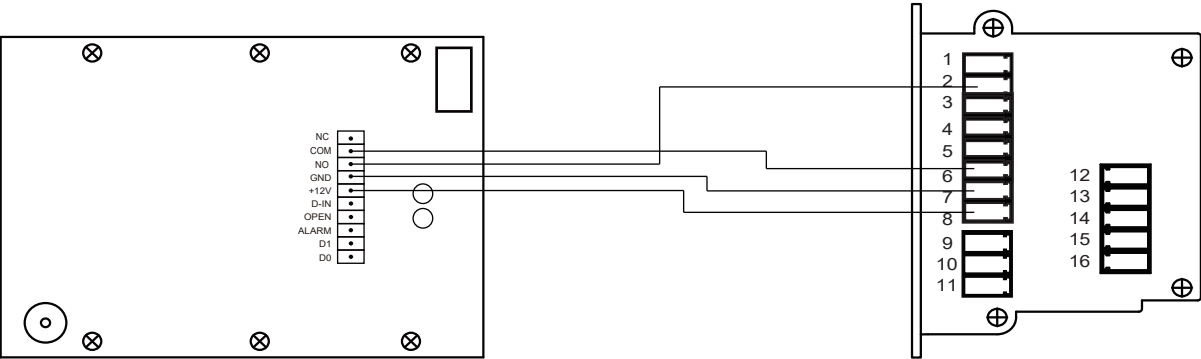

# Connection of inter-lock

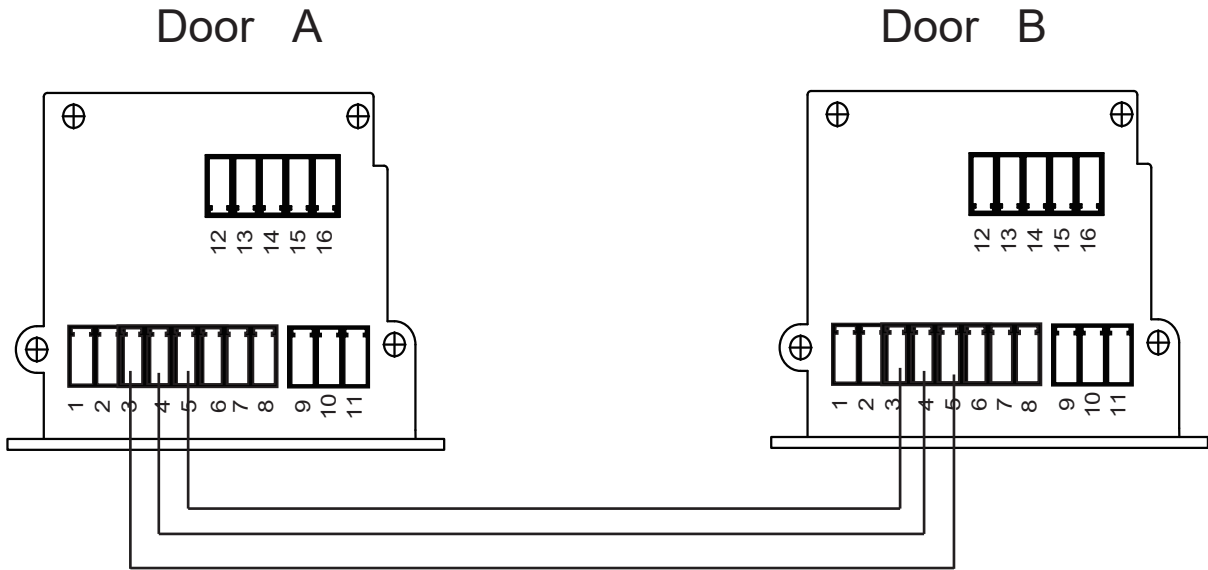

# Connection of photocell

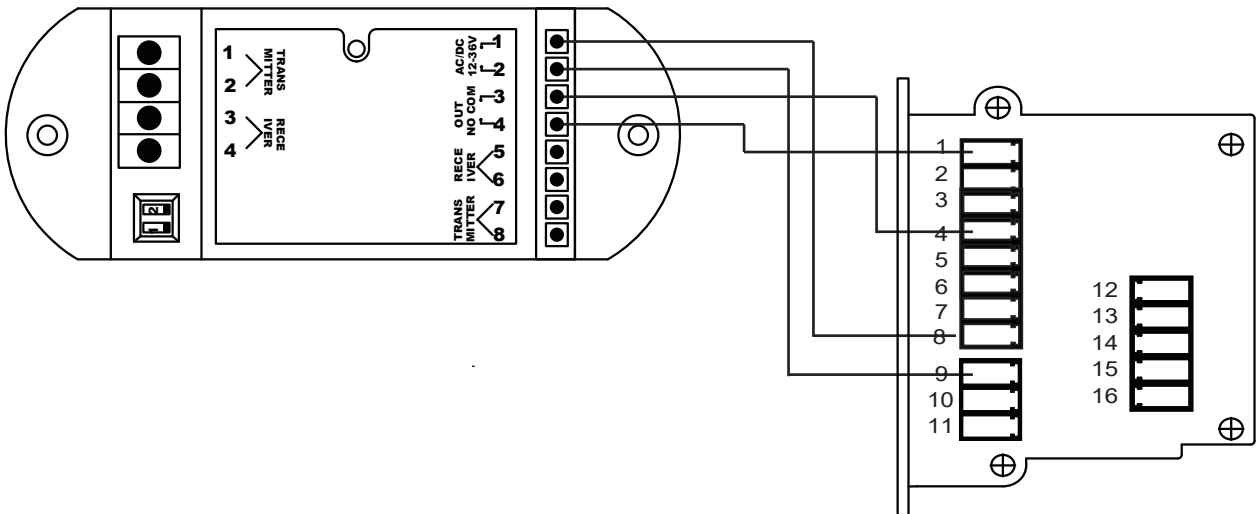

# Connection of UPS and Electronic lock

## ● Electronic lock

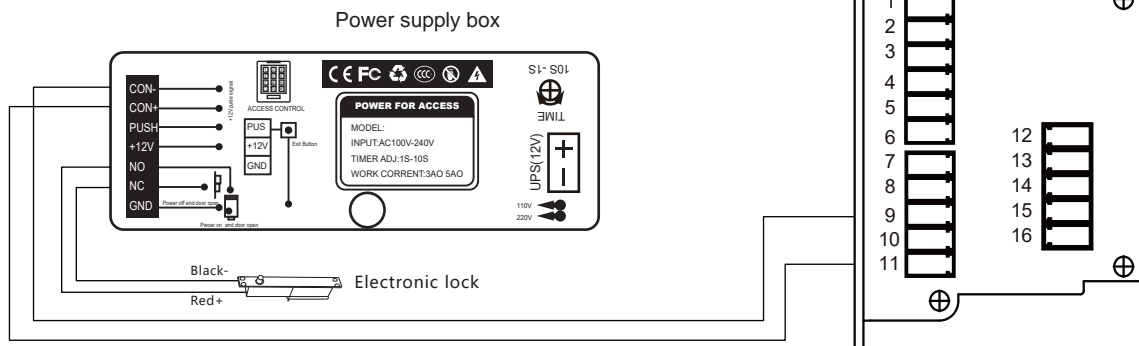

## ● UPS

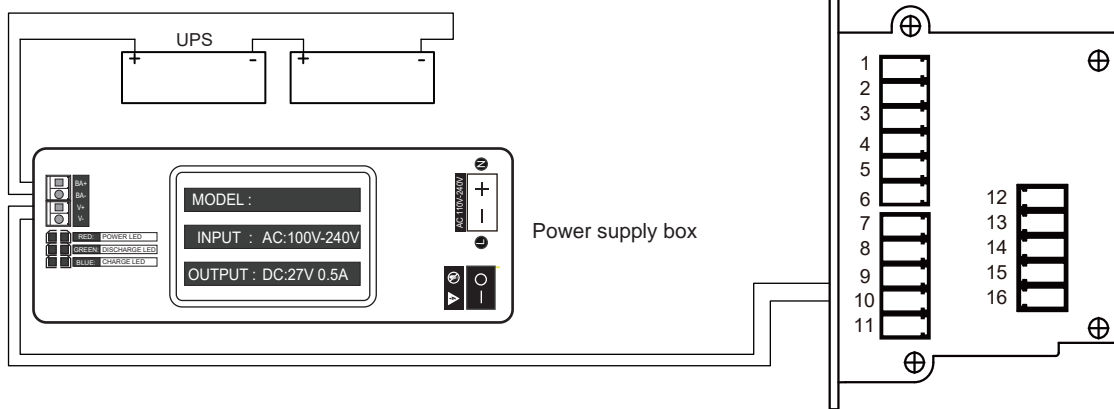

# Connection of remote(Rolling code)

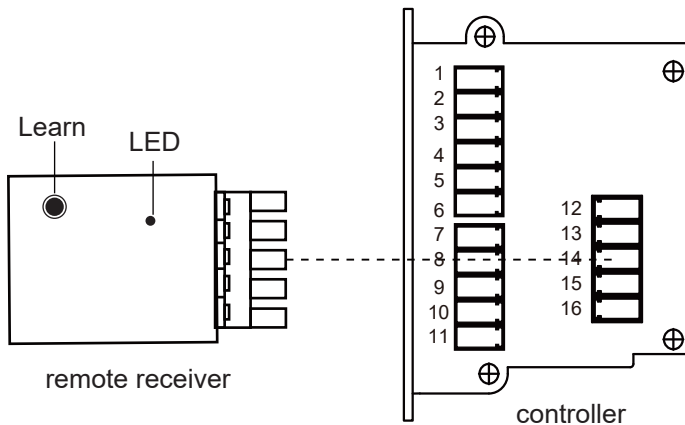

## NOTE

1. Notice the direction, insert the remote receiver into the controller terminal according to the chart
2. (Not connecting well will result in not working properly)
3. (All the connection operation should be done under power off situation)

## Open/Close breezer

Open the buzzer after pressing learning button 1second, then press 1 seconds again to close the buzzer, Switch mode circularly, when the buzzer ring once, it means switch successfully.

Indicator instruction:

- a. After closing buzzer, press the remote control, the buzzer not ring, red led indicator twinkling once
- b. After opening buzzer, press the remote control, buzzer ring one time, the red indicator not twinkling.

# Remote control function introduction

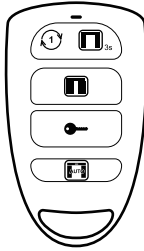

Remote



Short press: Open&Close  
Long press 3S: Full open



Half open



Full lock



Automatic

## Remote's learning and copy method

### \*Remote's learning method

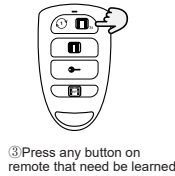
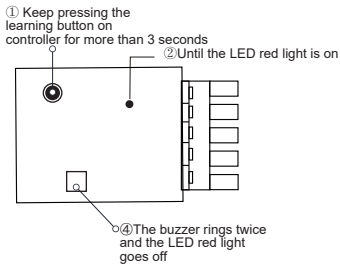

③ Press any button on remote that need be learned

### \*Remote's copy method

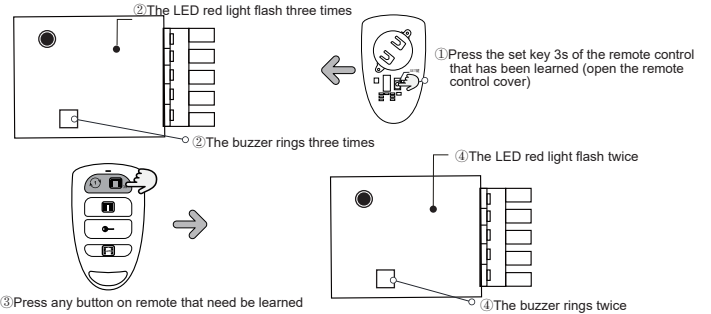

Note: All transmitters wireless switch (push button switch/Touchless hand sensor) can be directly learned in the same method as the remote.

## Remote's delete method

### \*Delete all remotes

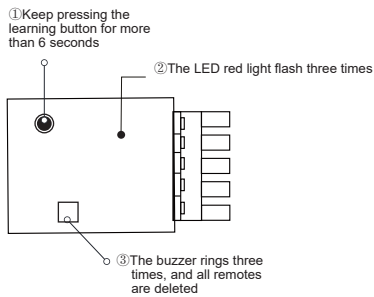

### \*Delete specified remote control

Note: Only one remote control can be deleted at a time.

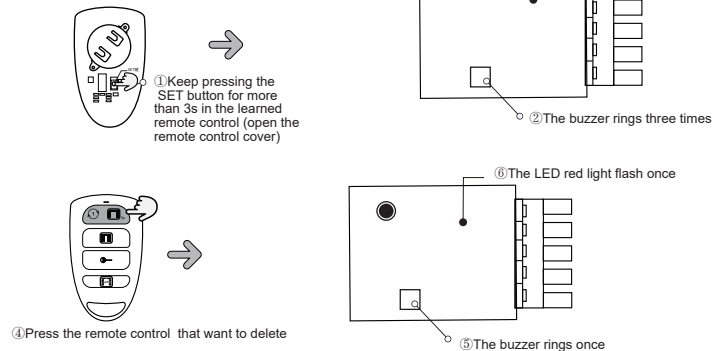

## Enable/Disable Memory function

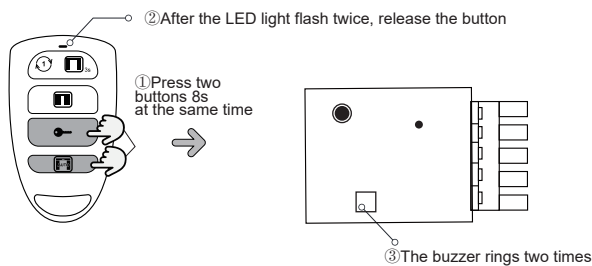

Enable Memory function  
(For example: Set to lock mode, power off and restart will still be lock mode)

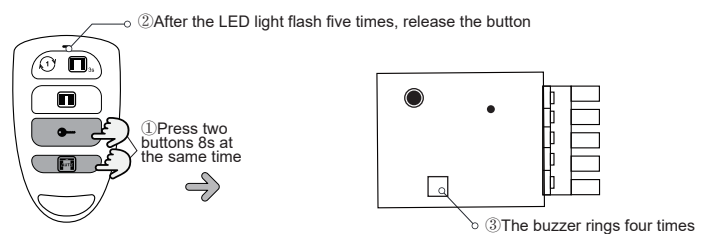

Disable Memory function  
(For example: Set to lock mode, power off and restart will release lock and turn to auto mode)

## Enable/Disable Full open function

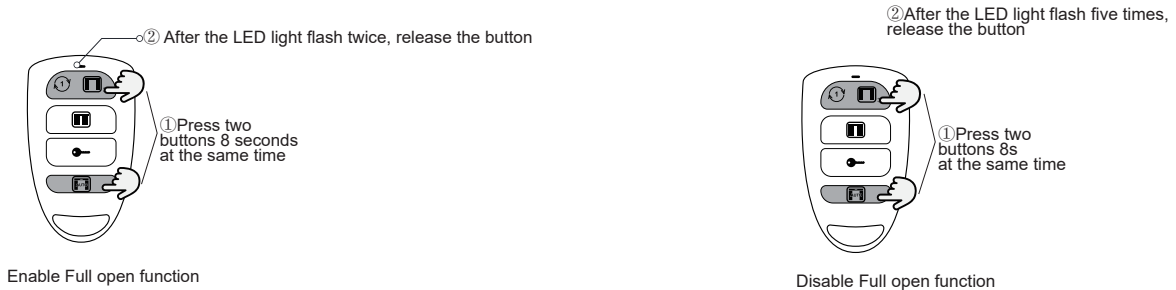

## Adjustment of open and close parameters

### Name and function of each component in the controller

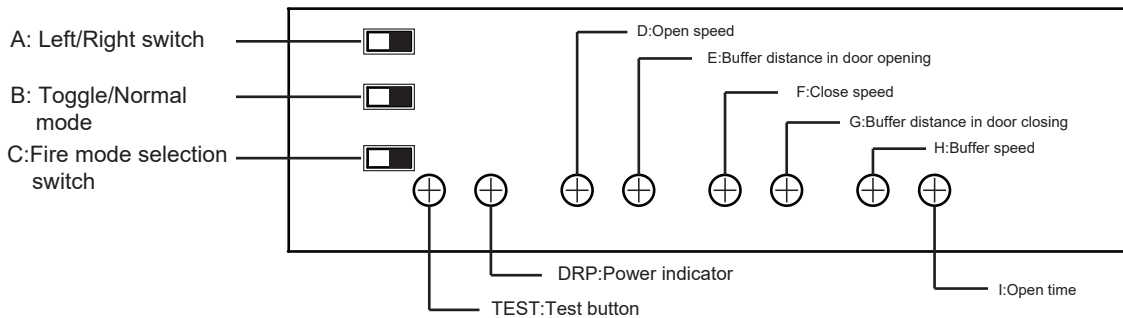

TEST: Press it, the door will open and close once; Used to check the operation of the door after adjusting parameters during installation

DRP: The lamp is always on after operation.

A: Left/Right switch, If the door keep open after the learning working distance during installation, please adjust the DIP switch A and relearn working distance again

B: Switch to left (toggle mode): Sensor once to keep open door, sensor again to close door;  
 Switch to Right (Normal mode): Sensor once, the door open and close once automatically

C: Switch to left: When backup battery working, the door will keep open;  
 Switch to right: When backup battery working, the door working normal (Door open and close automatically)

D; Turn counterclockwise, reduce the opening speed ; turn clockwise, increase it.

E; Turn counterclockwise, reduce the opening buffer distance ; turn clockwise, increase it.

F; Turn counterclockwise, reduce the closing speed ; turn clockwise, increase it.

G; Turn counterclockwise, reduce the closing buffer distance ; turn clockwise, increase it.

H; Turn counterclockwise , reduce buffer speed ; turn clockwise, increase it.

I; Turn counterclockwise , reduce hold open time ; turn clockwise, increase it.

DRP working status indicator information feedback:

LED On 1S off 1S -- in door working learning mode

LED On 3S off 3S -- in door normal automatic mode

LED fast flash once within 5S---Over current protection

LED fast flash twice within 5S---Motor error

LED fast flash three times within 5S---Electronic Lock stuck

Difficulty closing the door:

When the door repeatedly opens and closes 3 times because the door hits an obstacle, the door panel will stop in the position of the last resistance. After removing obstacles, give an opening signal to open the door again, and the door will open and close once then return to normal working.

## Adjustment of open and close parameters

### ●Regulation steps

(Regulation steps: open and close the door manually for several times to confirm the door can be Open and close freely)

(1) Left/right switch setting.

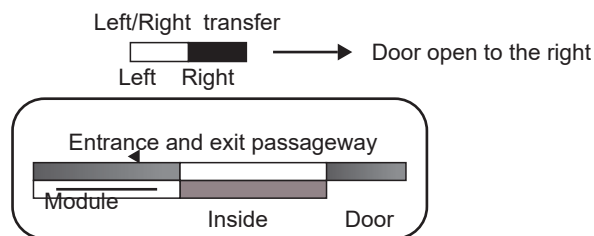

Viewing from the inside, left or right is set according to the open direction. For double-leaves door, the switch is set to the right.

(2) Unlocking delay switch is set. When electric lock is connected externally, align left, otherwise switch right without exception.

(3) The door is pushed to the close position and set initially.

(4) After switching on power, the door is opened slowly and closed after meeting with the stopper the door is under initialization. press the test button of the controller and regulate the buffer speed while opening and closing the door.

(5) When the door is closed, close speed and close slow down distance can be set as required.

(6) press the test button and set open speed and open slow down distance.

Press the test button of the controller, when opening the door, open speed and open slow down distance should be set as required.

Caution: when electric lock is in use, test button should be operated after unlocking

Caution: setting should be conducted after confirming that no pedestrian is around the door, otherwise injury may be caused

Caution: open slow down distance must be set to over 5cm, or will cause damage to the door.

(7) Regulate open time for the door

Set open slow down distance and set it to 10cm

set open speed

After confirming open speed of the door, set

Open slow down distance if necessary.

Caution: Never setting when door is opening or closing. Setting slowly as turning the button too fast will cause damage to the door or injury to personnel.

Press the test button of the controller. While opening and closing the door, set open time.

Caution: when electric lock is in use, test button should be pressed after unlocking.

# Trouble shooting

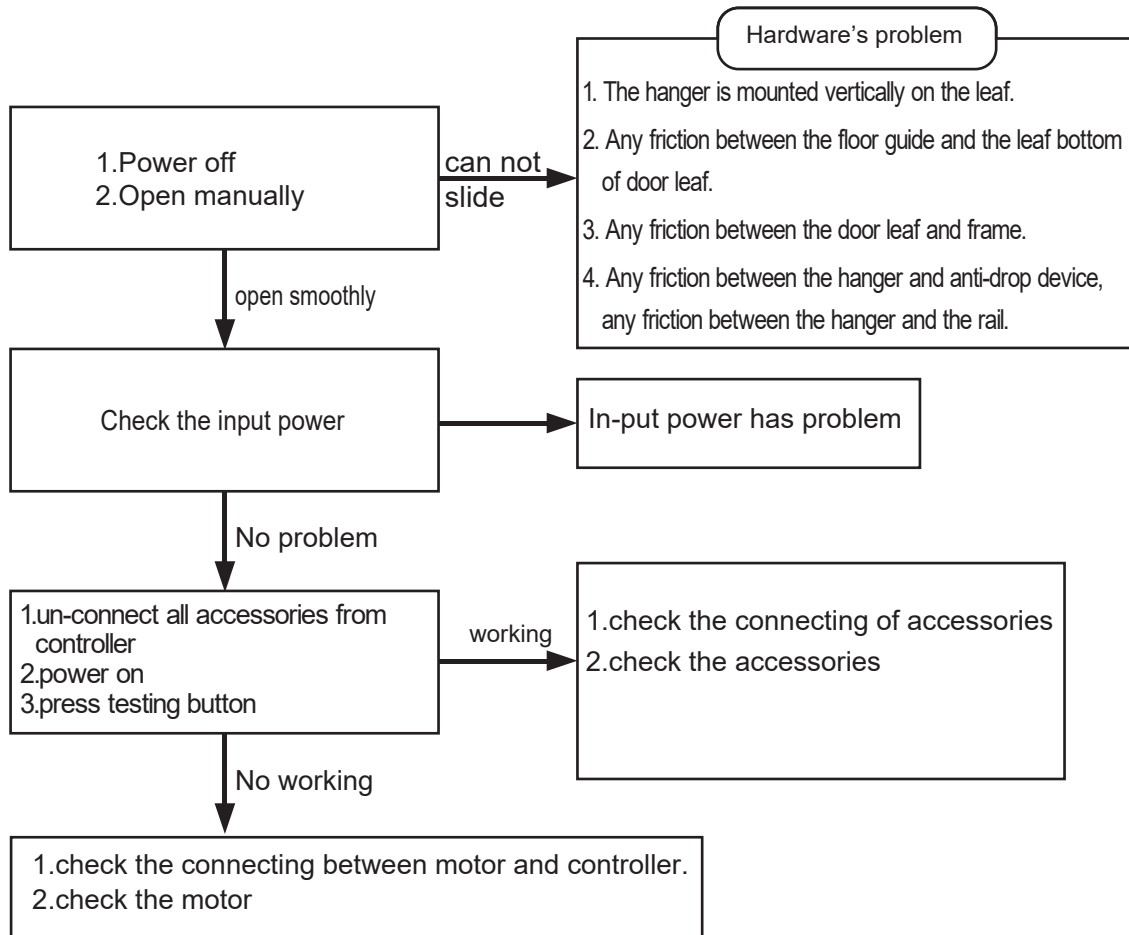

| Symptoms                                | Causes                                                                       | Troubles shooting                                                       | Remedy                                                                                        |
|-----------------------------------------|------------------------------------------------------------------------------|-------------------------------------------------------------------------|-----------------------------------------------------------------------------------------------|
| Door leaves open or close un-smoothly   | Opening or closing speed is set too slow                                     | Check the data of opening and closing speed.                            | Adjust the opening or closing speed.                                                          |
|                                         | Too much resistance when no power.                                           | Any damager or loosen at hangers, floor guide or anti-drop device.      | Fix the parts strongly.<br>Fixe the guide at the right position.<br>Fix the anti-drop device. |
|                                         |                                                                              | Any obstacle on the track.                                              | Clean the track.                                                                              |
| Door leaves hit each other when closing | Stopper is fixed not strongly.                                               | Check the stopper.                                                      | Adjust the stopper's position and fix it.                                                     |
|                                         | Closing speed is too fast and the buffer distance when closing is too small. | Check the closing speed and buffer distance when closing on controller. | Turn down the closing speed, and turn up the buffer distance when closing.                    |

## Trouble shooting

| Symptoms            | Causes                                               | Troubles shooting                                        | Remedy                                                 |
|---------------------|------------------------------------------------------|----------------------------------------------------------|--------------------------------------------------------|
| Door not working    | No power input.                                      | Check the outside input power.                           | Connection the power.                                  |
|                     |                                                      | Check the fuse of power switch.                          | Change a new fuse.                                     |
|                     | Door is locked.                                      | Check the lock is working or not.                        | Un-lock the door.                                      |
|                     | Connection between motor and controller is not good. | Check the connection is good or not.                     | Connect them strongly.                                 |
|                     | Inter-lock is working.                               | Check it works as inter-lock or not.                     | Waiting another door close.                            |
| Door does not close | Sensor is working.                                   | Check the sensor is broken or not.                       | Use a new sensor.                                      |
|                     |                                                      | Check any stuff at the detecting area.                   | Clean the detecting area.                              |
|                     |                                                      | Check the sensor is fixed stably.                        | Fix the sensor well.                                   |
|                     | Photocell is working.                                | Check the receiver and emitter are at same level or not. | Adjust position of receiver and emitter at same level. |
| Door does not close |                                                      | The surface of receiver and emitter is clean or not.     | Clean the surface.                                     |
|                     |                                                      | Connection is good or not.                               | Connect the photocell the controller well.             |
|                     |                                                      | Function keypad or remote is working.                    | Check the button of always opening.                    |
| Door open by itself | Sensor work mistakes                                 | Any stuff at the detecting area.                         | Move the stuff out the detecting area.                 |
|                     |                                                      | Any fluorescent light near sensor.                       | Don't install the fluorescent light near sensor.       |
|                     |                                                      | Any strong microwave machine working near sensor.        | Move the machine away sensor.                          |



