

2000KG SLIDING GATE

OPENER user's manual



- ★ Please read and follow all warnings, precautions and instructions before installation and use
- ★ Periodic checks of the opener are required to ensure safe operation.
- ★ For residential use only
- ★ Save this manual

1. Important safety information

Carefully read and follow all safety precaution and warnings before attempting to install and use this operator, incorrect installation can lead to server injury.

- *The gate operator should be installed by qualified technician; otherwise, serious personal injury or property damage may occur.
- *When opening or closing the gate, do not attempt to walk or drive through the gate.
- *Children should not be allowed to play near or operate automatic gates.
- *Install the gate operator on the inside of the property. Do NOT install it on the outside of the property where the public has access to it.
- *Be careful when in close proximity to moving parts where hands or fingers could be pinched.
- *The operator should be switched off before repairing it or opening its cover.

2. Main functions

The gate operator is used to drive the sliding gate. It is featured with powerful starting strength, capable of overload in a short time. When overloaded, it will be protected electrically. In the event of power failure, an emergency release key allows you to operate the gate manually.

3. Technical parameters

- * Power supply: AC110V/220V \pm 10v, 50Hz
- * Rate power: 550W
- * Motor speed: 1400r/min
- * Gate moving speed: 12m/min
- * Output torque: >20N.m
- * Limit switch: spring limit switch/magnetic limit switch
- * Environmental temperature: -10 to + 55 degree
- * Teeth: 19T/24T

4. Working principle and main structure

The dimension is shown in Fig.1. The gate operator is composed of a single-phase motor, worm and worm gear. The main shaft of the motor rotates the worm with the clutch engaged, the worm rotates the worm gear and output gear, which pushed racks attached to the sliding gates, thus moving the gate.

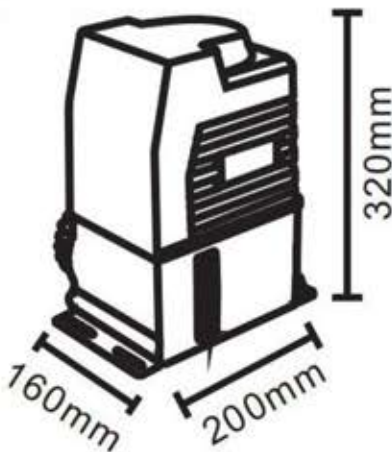

Fig 1

The structure of motor and worm is shown in Fig2. Output torque can be adjusted by pressure screw, tighten (or release) the pressure screw to increase (or decrease) the output torque.

Fig 2

The worm gear components are shown in Fig 3. It includes a pair of plastic gear clutches. In case of power failure you can use key to release the clutch, then the gate can be moved manually.

The gate operator is well lubricated and cooled by the cooling oil, which fills the whole gate operator, including the stator, the rotator of the motor, the worm gear and the worm.

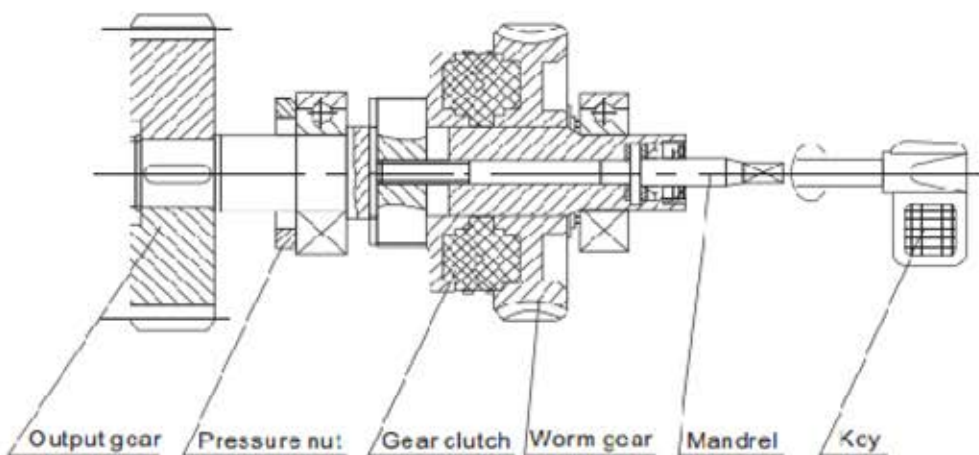

Fig 3

5. Installation and adjustment

The gate operator operates by forcing a drive rack past a drive gear. To guarantee the safety, it is highly recommend to install limit switch to prevent the gate from sliding out of the rails. The rails must be installed horizontally.

Conduit

In order to protect the wires, conduit must be preset into the concrete when it is poured. Wires within the conduit shall be located or protected so that no damage can result from contact with any rough or sharp parts.

Concrete Pad

The base unit of the gate operator requires a concrete pad in order to maintain proper stability. The concrete pad should be approximately 350mm*300mm*350mm deep in order to provide for adequate operation

Anchors

You can use the anchor bolts anchors, washers, and nuts. These anchors must be set into the concrete when it is poured, or you can use wedge anchors.

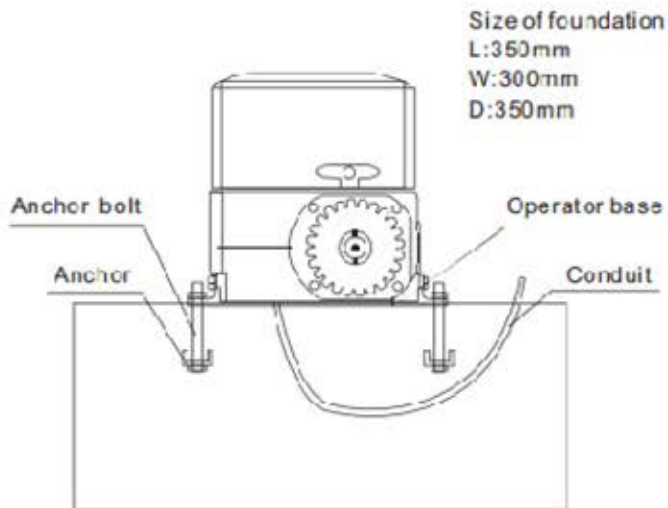

Fig 4

Operator Base

Mount the gate operator base to the concrete pad.

Operator

Mount the gate operator to the base using nuts and washers. Verify that the operator is leveled properly.

Installation of Rack (see Fig 5)

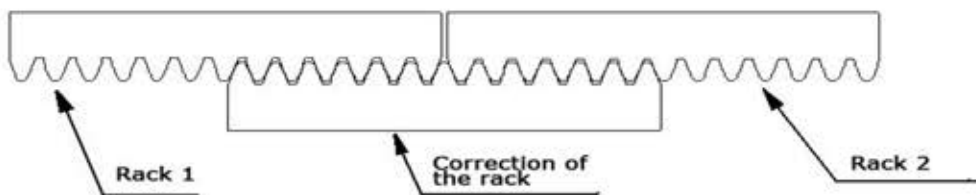

Fig 5

Spring limit switch

To ensure safety, it is recommended to install limit devices at both ends of the gate to prevent the gate from sliding out of the rails. The rails must be installed horizontally.

Install the plastic block as shown in Fig.6 and a Fig.6. The spring limit switch and blocks are used to control the position of the gate.

Release the gear clutch with the key and push the sliding gate manually pre-determine the position, fix the block to the rack and then tighten the gear clutch with the key. Moving the gate electrically, adjust the block to the proper position until the position of the opening and closing meet the requirement.

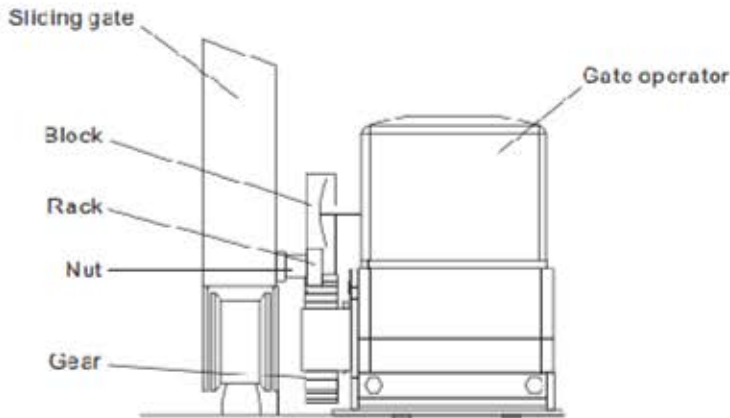

Fig 6

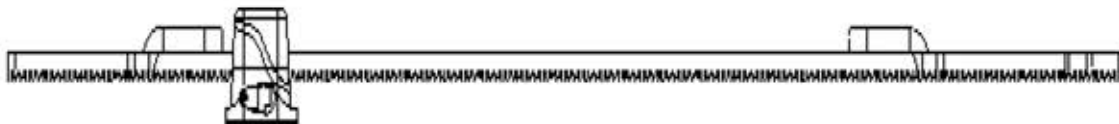

Fig 7

Manual operation

If the gate has to be operated manually due to a power cut or malfunction of the automated system, use the release key, as follow:

- * Fit the supplied key in the hole
- * Turn the key to release the clutch
- * Open and close the gate manually.

Note: If the gate bumps the mounting post and cannot be electric opened, move the gate back a few inches manually, thus you can release the operator with the key

6. Installation diagram of electrical parts (Fig 8)

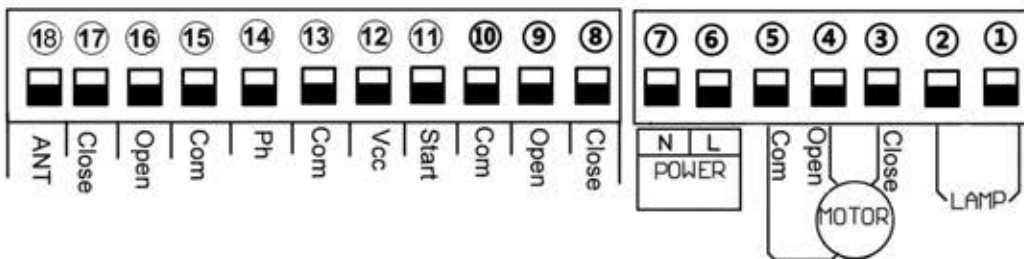

Fig 8

6.1. Terminal ⑥ and ⑦ it for connecting to 220V power

6.2. Connect to sliding gate motor Fig 9

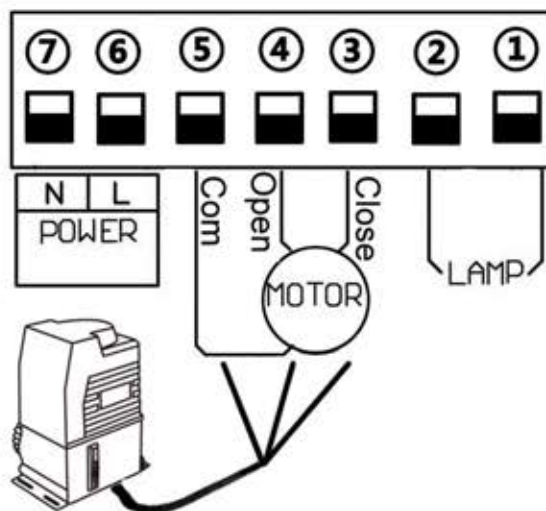

Fig 9

Terminal ③, ④, ⑤ is for connecting motor wire.

Terminal ③, ④ determines the forward and backward direction of the motor

Terminal ⑤ is terminal for Com(GND)

Please note: Our factory setting is install motor on the right of gate! When you want to install motor at the left of gate ,please exchange ③ and ④ motor wire .After exchange, please check if the motor can close and stop normally. If can't ,please up or down the "J1" to the opposite direction. ("J1" includes two pcs short circuit caps, you need to adjust the caps simultaneously, then it work)

6.3. Connect to flashing light. Fig 10

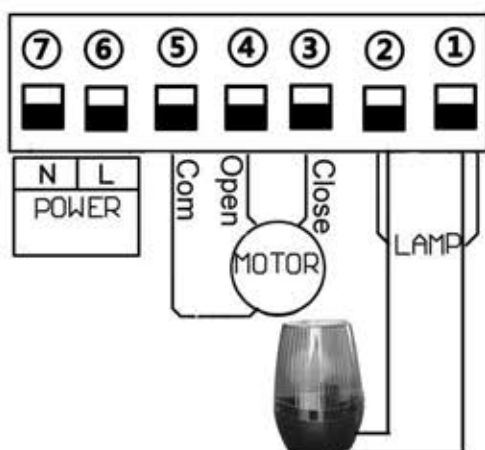

Flashing light Fig 11

Terminal ① and ② is for flashing light .

AC220V power output, flashing light on when motor start running, after motor stop 30s, the flashing light turn off

6.4. Terminal ⑧⑨ and ⑩ is for external limit switch.

6.5. Connect to infrared sensor. Fig12

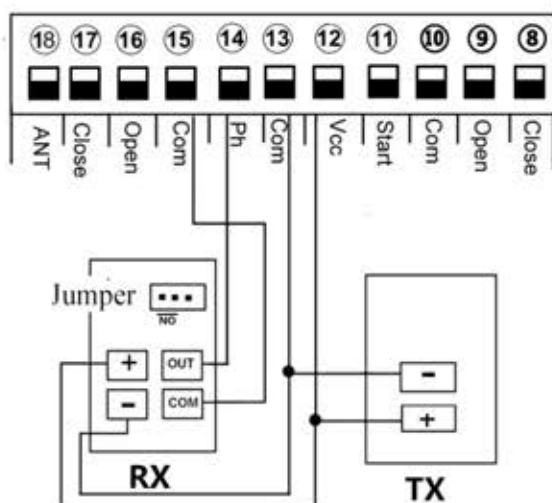

Fig 12

connect terminal ⑮ to the "COM "of photocell RX.

connect terminal ⑭ to the "OUT "of photocell RX.

Terminal is supplying power for external device.

So, connect terminal ⑫ to the “+” of photocell RX and TX.

connect terminal to ⑬ the “-” of photocell RX and TX.

6.6. Connect to start terminal. Fig 13

When you don't want to use the remote control to control the gate. Terminal ⑪ is for you connect some external device, such push button, wired keypad, receiver etc.

Control gate open, stop, close.

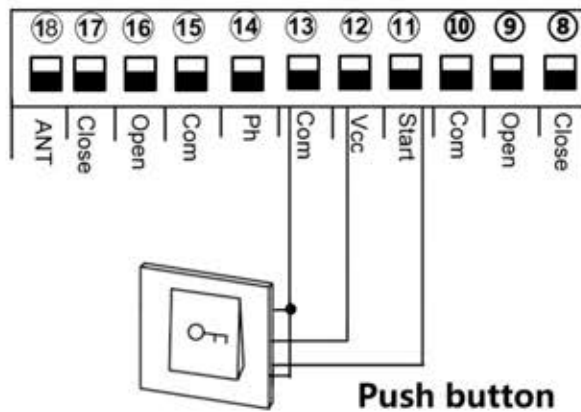

Fig 13

Example for push button;

Terminal ⑪ and ⑬ connect to push button. Terminal ⑫ and ⑬ to supply power for push button

6.7. Connect to open device. Fig 14

Terminal ⑯ is open only, for external device, such push button, wired keypad, receiver etc.

Only control gate open

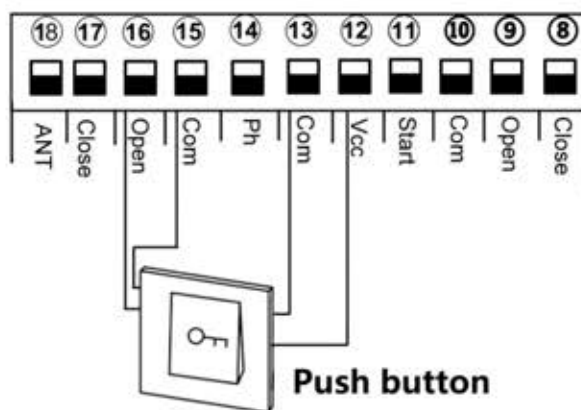

Fig 14

Example for push button;

Terminal ⑮ and ⑯ connect to push button. Terminal ⑫ and ⑬ to supply power for push button

6.8. Connect to close device. Fig 15

Terminal ⑰ is close only, for external device such push button, wired keypad, receiver etc.

Only control gate close

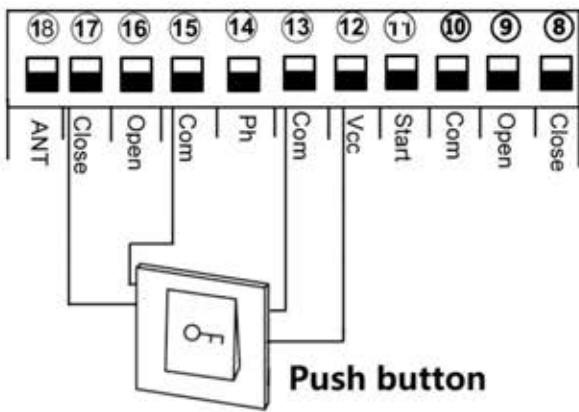

Fig 15

Example for push button;
Terminal 15 and 16 connect to push button. Terminal 12 and 13 to supply power for push button

7.Function Testing

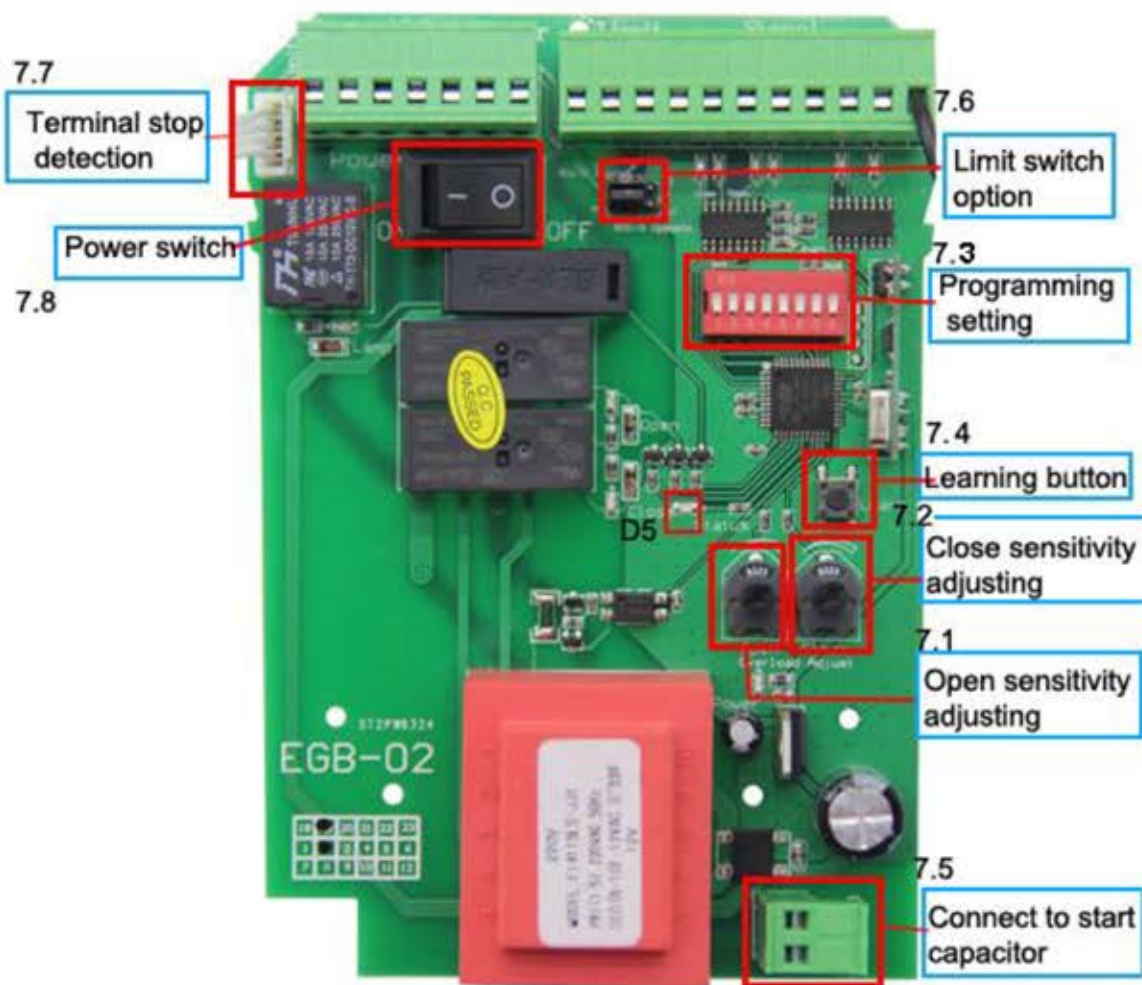

Fig 16

The following functions refer to the picture Fig 16

7.1 Gate open blocked detection: Fig 17

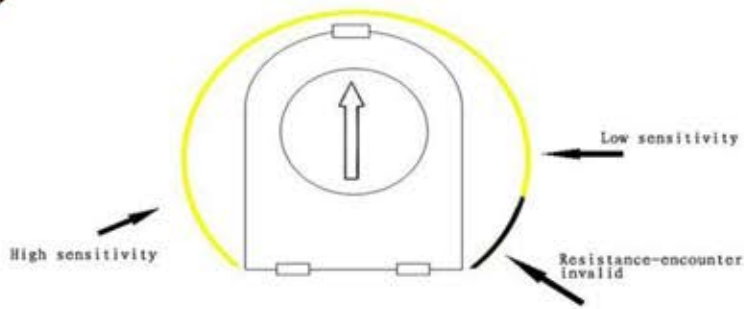

Fig 17

As picture show, we can rotate "Open overload " potentiometer to adjust the motor open sensitivity of blocked

- A. High sensitivity : when the motor is rotation, will meet some minor resistance, then control board will send a signal to let motor stop rotating.
- B. Low sensitivity : when the motor is rotation, will meet greater resistance, then control board will send a signal to let motor stop rotating.
- C. As picture show , when pointer rotate to black part ,the control panel will quit this system

7.2 Gate close blocked detection: Fig 18

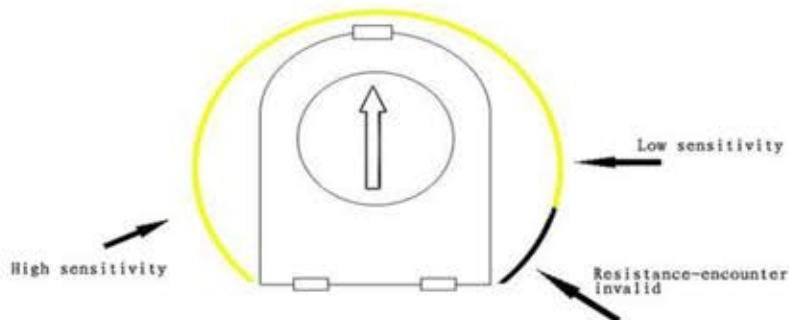

Fig 18

As picture show, we can rotate "Close adjust " potentiometer to adjust the motor close sensitivity of blocked

- A. High sensitivity : when the motor is rotation, will meet some minor resistance, then control board will send a signal to let motor stop rotating.
- B. Low sensitivity : when the motor is rotation, will meet greater resistance, then control board will send a signal to let motor stop rotating.
- C. As picture show , when pointer rotate to black part ,the control panel will quit this system

7.3. programming setting:

A. Dial-up 1: Limit mode optional

OFF: NC mode(Factory setting)

ON : NO mode

Limit switch direction setting(J1):

Normal :Short circuit cap simultaneously No1 and No2 of J1 (Factory setting)

If motor system install at left of gate . Please adjust the J1 ,short the cap simultaneously No2 and No3

B. Dial-up 2: Infrared mode

OFF: NC mode(Factory setting)

ON: NO mode

If the gate meet obstacles during closing, It will auto stop and auto open. After The gate complete open to its place, it will auto close again if the obstacle disappear within 2s, if not , it will not auto close until to the obstacle disappear

C. Dial-up 3 &4: Auto close time setting

Auto close function activated after gate complete open to its place and stop by limit switch

Dial-up 3 &4, OFF-OFF: Auto close function disabled(Factory setting)

Dial-up 3 &4, ON-OFF: 10S

Dial-up 3 &4, ON-ON: 30S

Dial-up 3 &4, OFF-ON: 60S

D. Dial-up 5&6: Auto close time setting when pedestrian mode activated

When remote control triggers the pedestrian mode (remote control button 2 or 4), the gate will stop after open 6s. If auto close function activated, the gate will auto close after gate open to 6s. Auto close time setting as follows:

Dial-up 5 &6, OFF-OFF: Auto close function disabled(Factory setting)

Dial-up 5 &6, ON-OFF: 5S

Dial-up 5 &6, ON-ON: 10S

Dial-up 5 &6, OFF-ON: 30S

Note:

1. When the motor is running, the motor will stop immediately if triggers pedestrian mode
2. After triggering the pedestrian mode to open the gate for 6s, no matter it enter the countdown to close the gate or stop status, if trigger again, the gate will close the gate immediately.

E. Dial-up 7: Condominium mode setting

OFF: Condominium mode disabled(factory setting)

ON: Condominium mode activated

When the gate is opening, trigger remote control and the start interface are invalid until the door is opened.

When the gate is closing, trigger remote control and the start interface, the gate will stop to close and auto open until the opening limit is reached (the remote control and the start interface are invalid when the gate is opening).

E. Dial-up 8: Remote control buttons mode

OFF: Single button control circularly

First button control gate open, stop, close, second button use for pedestrian mode

ON: Three buttons control

First button control gate open, second button control gate stop, third button control gate close, fourth button use for pedestrian mode

Not: Please choose the remote control mode firstly before remote control code clearing to control board

7.4 Learn remote control code:

A. Control panel can memory more than 50 pcs remote control

B. Code learning: Press board "LEARN" button, LED indicator light on, press remote control first button, LED indicator flash twice, code learning succeed. If no remote control signals received within 2.6s, the receiver will automatic quit learning functions.

C. Code clearing: Press and hold the button 6 seconds, LED indicator flash twice, all the code that has been memorized in control board will be cleared

7.5 Motor Start Capacitors:

Capacitors are connected with control board before use motor, please confirmed the interface of capacitors is secure. Please see picture Fig 16

7.6 Limited switch options (J1):

Limit switch is used to switch terminal stop detection interface, that direction of open and close the gate

7.7 Terminal stop detection interface:

Terminal for limit switch, such as spring limit or magnetic limit .

7.8 Power switch:

Switch on /off power stop when do some setting on the control board

8.Trouble Shooting

Problem	Possible causes	Repair method
Gate fails to operate	1. Check the clutch states ,power-driven state or not 2. Power no indication, and power trip. 3. The fuse has broken 4. Remote control failure or invalid 5. Damaged power cable 6. Remote control or motor problem	Recovery To restore power Change the fuse Detection or change Detection and Repair Detection and Repair
Working distance of remote control reduced	1. Low battery power or damaged 2. Interference from equipment using the same frequency 3. The receiver of controller was damaged	Replace battery Wait eliminate interference Replace the control board
Gate fails to stop at start or end position	1.The terminal stop toggle switch is damaged or obstructed. 2. Limit switch of the motor and the limit detection of the interface PCB board plug off. 3. Limit of open and close is in wrong position.	Replace toggle switch or remove obstruction Insert and fixed it Adjust of limit switch(K1)
Press open and close key of motor, but cant working and operate	1. Blocked sensitivity is too high(set too big) 2. The gate has lifted off the track and disengaged the drive gear from the rack	Make blocked sensitivity lowered ,and check gear and racks can operate normally. Maintenance and replace.

9. Important Notes

1. When someone or obstructions between the gate, do not open or close the door to ensure safety.
2. The power supply for the control board should be equipped with a separate switch with a fuse rated at 10AMP.
3. There is strong electricity in the control box. Please cut off the power supply before opening the cover.
4. Motor gear modulus $M = 4$, number of teeth = 16, use the corresponding racks
5. the gate should be as straight as possible, making sure after racks fixed good and the gate can be in a good position with motor gear.
6. Racks and gear should be controlled in good gap. so can make sliding steady.
7. After confirm the direction of gate movement . please check if the limit block fixed in good position to avoid the motor run out of control due to failure