

2000K ROLLING SHUTTER MOTOR INSTRUCTION

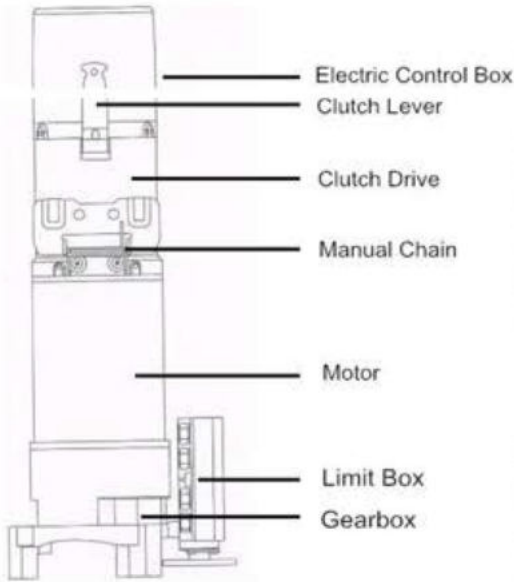

STRONG
— Heavy Duty —

Rolling Door Motor Instruction



Motor

Advantage:

1. Light and handy, superior quality

All of the components are well-designed, quality of which are under strictly control. And the motor case are pressure-cast with high strength aluminum alloy, and good-look appearance. The surface is electrostatic sprayed by power and baking finished so that it may not easy to fade or get rusty.

2. Low noise, long cycle life

Reduction gear is made in high class cuprum alloy proceeding by precision gear and heat treatment, low noise. The solenoid brake components are made of brake material of the advanced car, so that the cycle life is very long.

3. High power and fast

The motor is optimum-designed, all components of which are made in superior materials, and is powerful, fast rolling, time-saving and energy-saving.

3. Power failure

When the power is failure, pulling the chain by hand may lift the door up, and pulling the clutch lever may let the door down.

4. Easy operation, safety and security

There are several ways of controlling, by using remote controller, hand control, and pulling chain by hand when power is failure. And to keep from breaking in, you could also lock the hand controlling by remote controller.

5. Easy to assemble and protect

Insert the host machine into the side sheet, no more drive chain needs, so it saves time and power. The electric control panel is designed of inserting style, so it's easy to change the components. It's always available to drive doors of garages, shops, malls, exhibition halls, museums, factories, warehouses and so on.

AC Motor Technical Specification

Model	Voltage V/Hz	Rated Power W	Rated current A	Rated Load			Max raising height M	Short- team ration MIN	Own weight dropping torque KG	Standard drum diameter INCH	Control way
				Lifting weight KG	Output Torque N.m	Output Speed RPM					
2000kg-3P	380/50	1000	4.1	2000	2450	3.6	12.0	13	≤48	8	Remote control and manual chain

Operational environment:

Temperature: -25°C~50°C

Highest relative humidity: 95% (25°C)

Power: single-phase 220VAC±10%, 50~60Hz

Operating: 10 minutes continuous operation at most

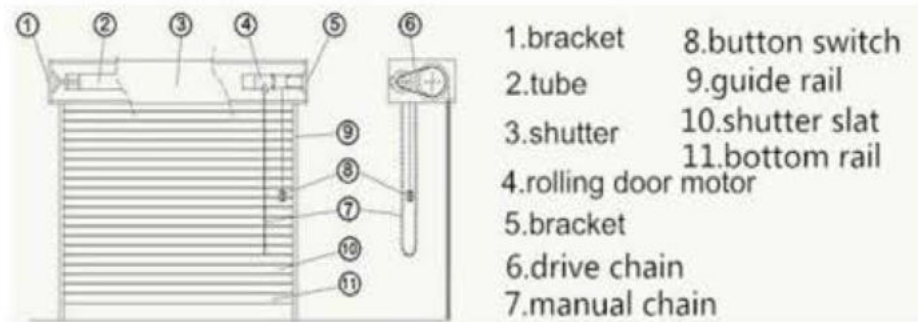

Assembling

Assembling step:

1. According to the door height, install the bracket to both sides with expanding screws, and weld. Notice that the bearing side and motor side should be on the same level.
2. Vertically install the tracks proper to the sides of door.
3. Calculating length of steel pipe and shaft and steel discs then weld.
4. Insert the shaft into the bearing with bearing bracket, and fix the motor with the tube.
5. Install the motor to bracket, and adjust the two M6 hexagon screws of the motor to make the chain elastic, then fasten the four M10 nuts of the bracket.
6. Put the shutter roll on the tube, then operated the motor up and down, let shutter run along into tracks, then adjust the up and down limit position.
7. From indoor to outdoor, if install the motor on the left side, revolve the clutch drive by 180 degrees, then exchange the black and white wires of the button as well as the yellow and white wires of the controlling. If install on the right side, nothing needs to be changed.

Trouble shooting:

Troubles	Causes	Deal with
Motor's responseless	1. Fuse is burned	1. Change a fuse
	2. Wire's not connected	2. Connect the wire
	3. Continuously running more than 10minutes	3. Wait for the motor cold down
Motor's out of control	1. Adhesion of the relay contacts	1. Change a relay
	2. Button's watered	2. Remove the water
The door slides down after off the motor	1. The drive's failure	1. Change a brake plate
	2. Clutch liver's pressed	2. Remove the obstacles
Up and down limitation changes badly	1. Limit stop is wore or torn	1. Adjust the limitation
	2. Switch of the stopper's worn out	2. Change a switch
Noisy	1. Chain's loose or tight over	1. Adjust the chain
	2. The door and the tracks rub too much	2. Add some grease
	3. The bearing is worn out	3. Change a bearing

DC Motor Introduction:

This product use optional power, that in normal power supply situation, motor drive with power by utility. If having a power off for its electrical automatic power reserves, that can ensure door motor run about 20 times in normal.

Feature of Product:

1. Attractive appearance, advanced structure, strong horsepower;
2. Configuration high-power low loss ring transformer, utility can direct drive motor;
3. Low noise, small vibration, low consumption;
4. Light weight, small size, convenient installation, long life and reliable performance;
5. With convenient, stable function of remote control, can distance remote operation;
6. Reserve power supply is used batteries for universal product(4.5Ah! 24V);
7. Controller of energy conservation and environmental protection lighting, delay cabin for 3 minutes.

DC Motor Technical Specification

Model	Voltage	Rated Power	Rated Load			
			Lifting force	KG	Output torque N.m	Output speed RPM
300kg	24V±10%/ 50Hz	150	300		168	3.7
300kg	24V±10%/ 50Hz	200	300		168	4.9
500kg	24V±10%/ 50Hz	240	500		345	4.6
600kg	24V±10%/ 50Hz	240	600		412	4.2
800kg	24V±10%/ 50Hz	380	800		650	3.9

Trouble shooting

Troubles	Causes	Deal with
Under voltage alarm (the storage power user)	After installed, at first use, appear under voltage alarm.	Charging
	The AC power cut out for more than two days, when you use appear under voltage alarm.	Charging
	After 10 hours of charging, when you use appear under voltage alarm.	Replace Battery
When reaching above or below, but does not stop	Motor phase sequence is wrong, up, down position limit failure.	Cut off the power, check and adjust the phase sequence.
Don't run.	Push. button contact is poor, limit switch is stuck, circuits are not working.	Adjust or replace of button, exam the wiring, restore.
Constantly running.	Relay contact fusion, limit switch failure.	Repair or replace of the relay, slight move switch.
Have sound, but no work.	Clamping stagnation, input voltage is below 190V.	Deal with the clamping stagnation, charging.(the storage power user)
After the brake, doors continue to decline.	Axial brake pads is excessive wear.	Check compression spring, increase the adjusting washer