

1200 KG SLIDING GATE

OPENER user's manual



STRONG
— Heavy Duty —

Contents

1. Summary	(1)
2. Appearance and dimensions	(1)
3. Parameters	(1)
4. Features of control board	(2)
5. Installation of mechanical parts	(2)
5.1 Installation of motor base plate	(2)
5.2 Installation of gate opener	(2)
5.3 Installation of racks	(3)
5.4 Installation of limit levers	(3)
5.5 Function of clutch	(3)
6. Installation diagram of electrical parts	(5)
7. Function Testing	(7)
8. Maintenance	(10)
9. Trouble Shooting	(10)
10. Important Notes	(11)

1. Summary

This equipment is one of the auto gate openers launched by our company adopting a new design and integrated control system. Our new sliding gate opener has many features such as: low noise, light weight, powerful starting torque, stability, reliability and is compact and stylish. The motor will still work for a short period of time using lower voltage. The control board has overload protection. When there is a power failure, the motor drive can be separated by the use of the clutch, by using the specified key the user has the ability to disconnect the clutch enabling the gate to be opened or closed manually. Using the optional infrared photocells the gate will automatically stop and re-open if an obstacle is sensed.

2. Appearance and dimensions

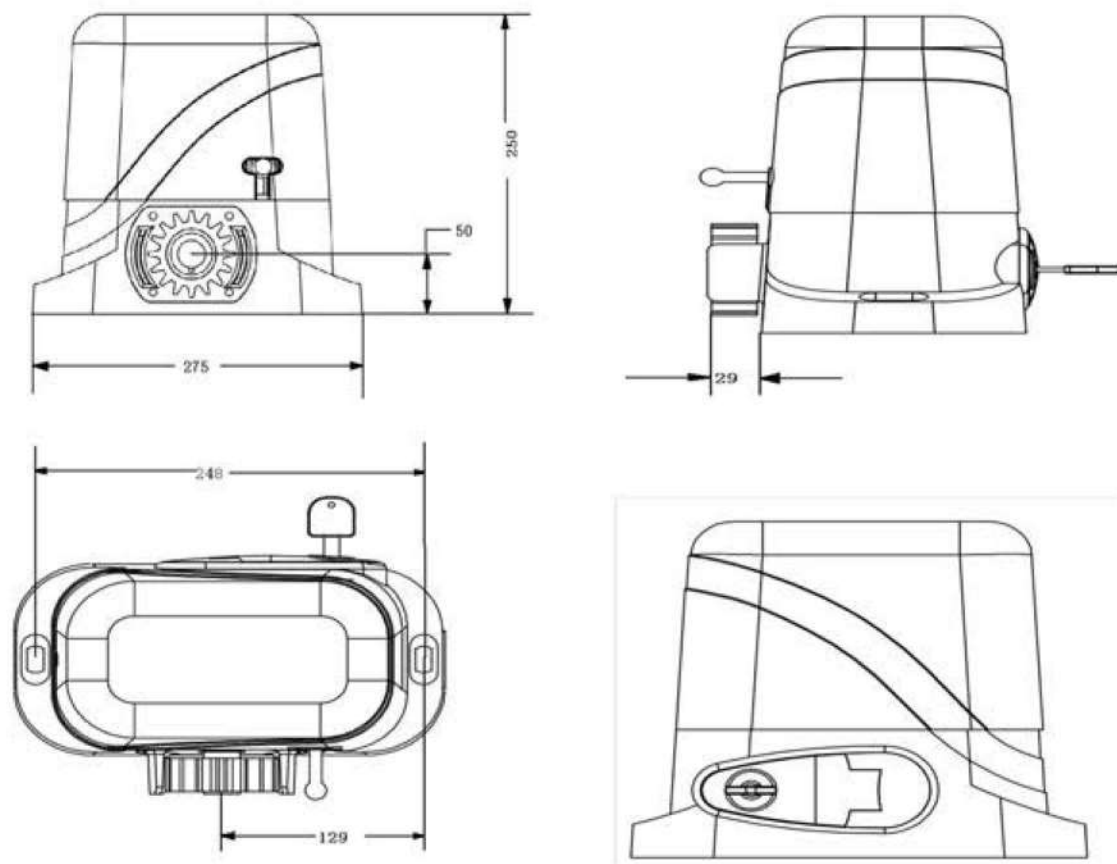

Fig 1

3. Parameters

1. Working temperature of motor: $-25^{\circ}\text{C} \sim +55^{\circ}\text{C}$
2. Working humidity: $\leq 85\%$
3. Power supply: $220\text{VAC} \pm 10\% / 110\text{VAC} \pm 10\%$ 50Hz/60Hz
4. Rated power: 350W
5. Output gear module: $M=4$
6. Output gear number: $Z=16$
7. Output torque: 30.0 N.m
8. Open(close) speed: $v=12\text{m/min}$
9. Rated speed : 1400RPM
10. Maximum pull: 1100N
11. Maximum load: 1200kg

- 12. Net weight: 11KG
- 13. Remote control distance : ≤ 50 meter
- 14. Packing : In a standard carton
- 15. Protection Class : B

4. Features of control board

- 1. Totally integrated electrical mechanical system (excludes racks)
- 2. Control board interface for optional impact-proof infrared photocells
- 3. Alarm lamp interface
- 4. Automatic delayed closing
- 5. Adjustable resistance sensitivity
- 6. Gate will auto stop and re-open when an obstacle is encountered
- 7. Wireless remote control or wired remote control are optional

5. Installation of mechanical parts

5.1 Installation of motor base plate

- 1. Depending on the installation size of the motor and mounting height of racks, after determine the installation position of the motor base plate, first let the bolt embedded or use expansion bolt to make base plate fixed on watering good cement foundation. See diagram 2

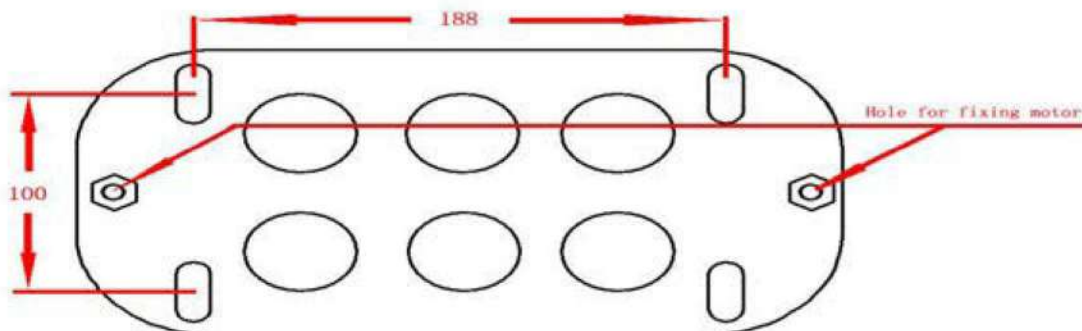

Fig 2

- 2. If the rack has been installed on the door, the motor can be fixed on the base plate. use a Allen key rotation to the clutch "off" position, the motor and the gear rack so as to better determine the position of the motor base plate, then remove the motor and fixed base plate.

5.2 Installation of gate opener

- 1. Let the sliding gate opener put on the base plate. use a random matching hexagon screw make the motor fixed on the base plate.
- 2. Unscrew the screws fixed the motors cover, and then remove the motor cover. according to the electrical wiring diagram, connected the power cord, after adjust in good position, Then install cover and use screws to fixed it

5.3 Installation of racks

- 1. After the motor is installed, the racks teeth the down, then put the gear on the motors. and final connected with screws and gate. push the door with hand. so can let door sliding it and can move it without any problem. after confirmed, fixed the racks.

2. Rack is usually unit assembly, in order to avoid gate run jitter or jammed, rack and joint clearance must be corrected. Suggest use this way, see diagram 3. with a small correction of the rack, after connecting right with racks 1 and racks 2, then fixed racks 1 and 2.

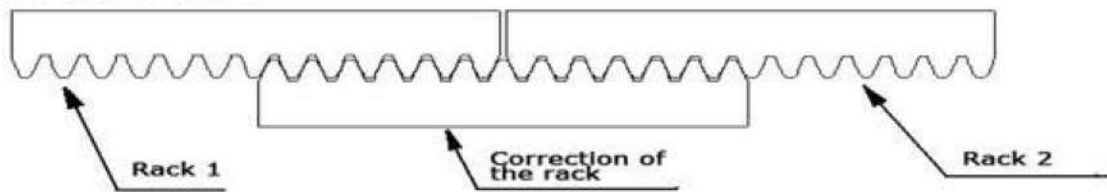

Fig 3

5.4 Installation of limit levers.

There are 2 limit levers supplied. Note there is a left hand and a right hand lever. The levers should be installed one at either end of the rack. See Fig5.

To install the levers in the correct position, open the clutch door and press the 'CLOSE' button on the remote, the motor will run but will not drive the gate. Close the gate manually and adjust the limit lever to contact the toggle switch and switch the motor off at the desired gate position. To adjust the stop position of the gate when it is open, press the 'OPEN' button, manually open the gate and adjust the other limit lever to contact the toggle switch and switch the motor off.

When you are satisfied the levers are in the correct positions, tighten the screws in the levers to clamp them to the rack, close the clutch door and using the remote control check the gate opens and closes to the desired positions. Adjust the limit levers if necessary.



Fig 4

5.5 Function of clutch

When the clutch is opened to the open position, you can manually push the door; when closing the clutch, electric door can run on, off, when touching limiting the bezel will stop automatically.

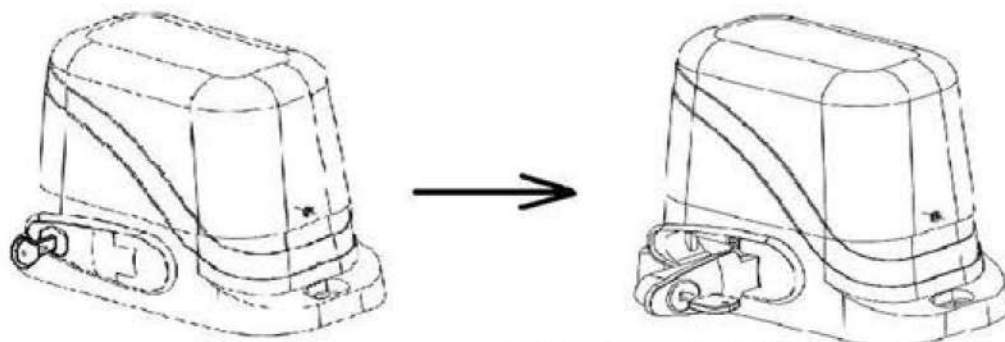

Insert key, rotate 90 degrees CW

Releasing arm in torsion, wriggle 90 degrees, gate operator will be in releasing state.

Fig 5

6. Installation diagram of electrical parts (Fig 6)

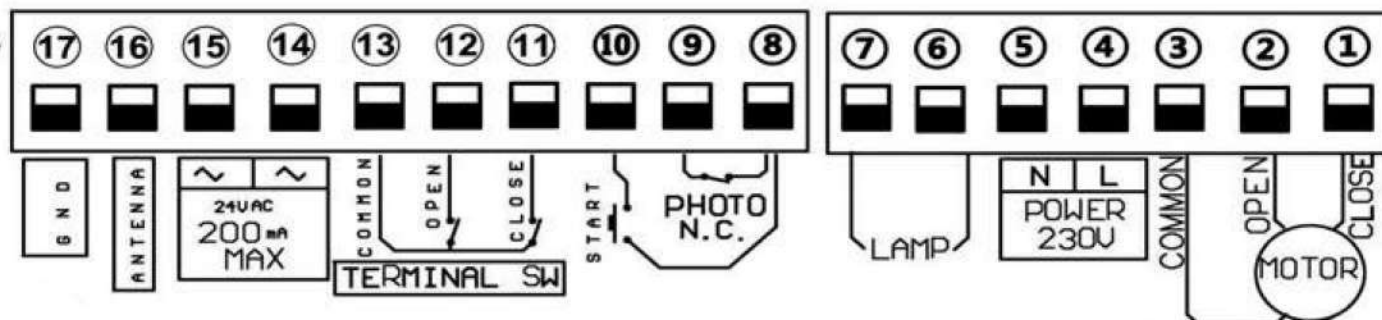

Fig 6

- 6.1. Terminal ④ and ⑤ it for connecting to 220V power
- 6.2. Connect to sliding gate motor
 - 6.2.1. Install the motor on the right of gate. (Please see Fig 7)

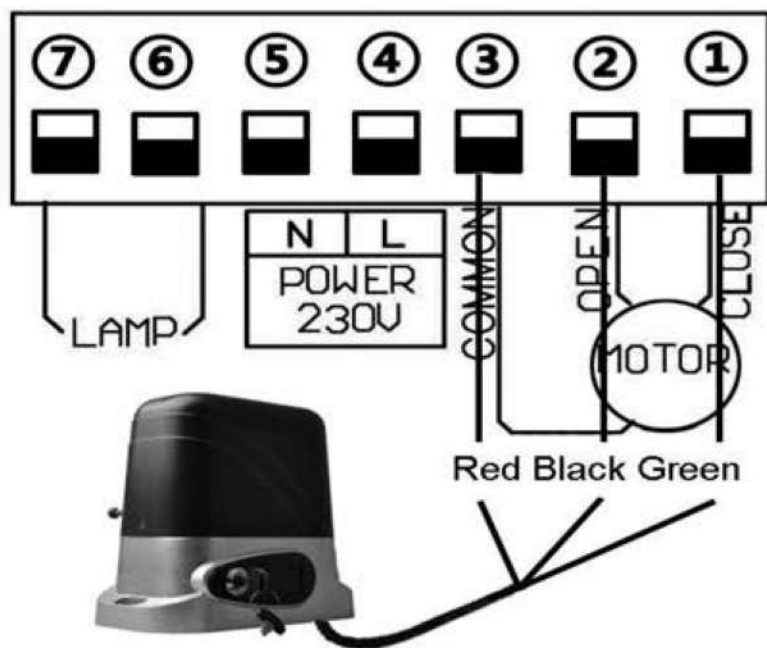

Fig 7

- When the motor being installed to the right of gate , motor wires diagram follows
- Terminal ① connect the green wire from motor.
 - Terminal ② connect the black wire from motor.
 - Terminal ③ connect the red wire from motor.

Please note: Our factory setting is install motor on the right of gate!

- 6.2.2. Install the motor on the left of gate. (Please see Fig 8)

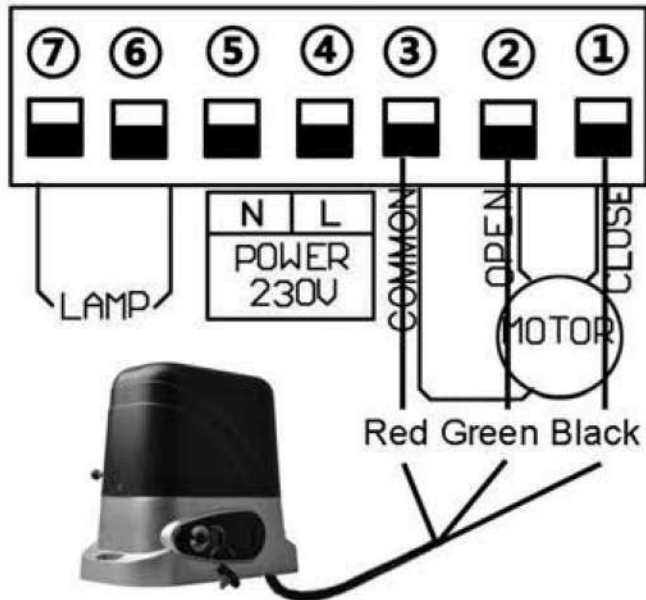

Fig 8

When the motor being installed to the left of gate , motor wires diagram as follows:

- Terminal ① connect the black wire from motor.
- Terminal ② connect the green wire from motor.
- Terminal ③ connect the red wire from motor.

Please note : When you exchange white and blue wire, please check if the motor can close and stop normally. If can't ,please up or down the “K1” to the opposite direction.
Note: “K1” includes two pcs short circuit caps, you need to up or down the caps simultaneously, then it work.

6.3.Connect to flashing light. (Please see Fig 9)

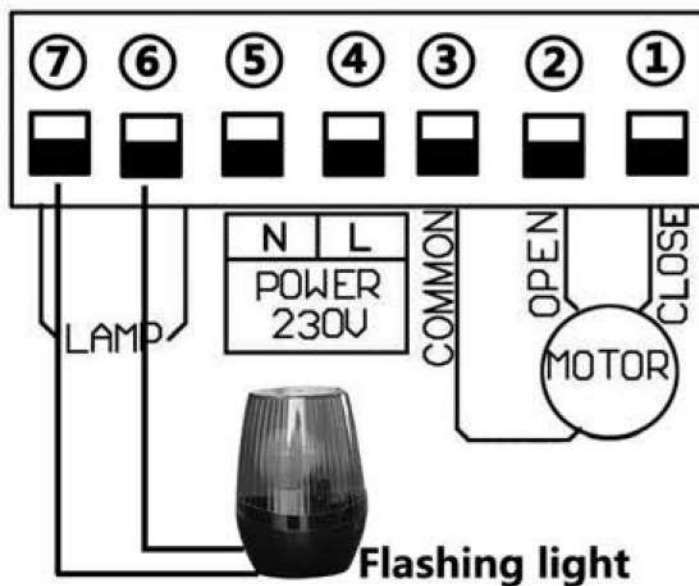

Fig 9

Terminal ⑥ and ⑦ is for flashing light .

6.4. Connect to infrared sensor.(Please see Fig 10)

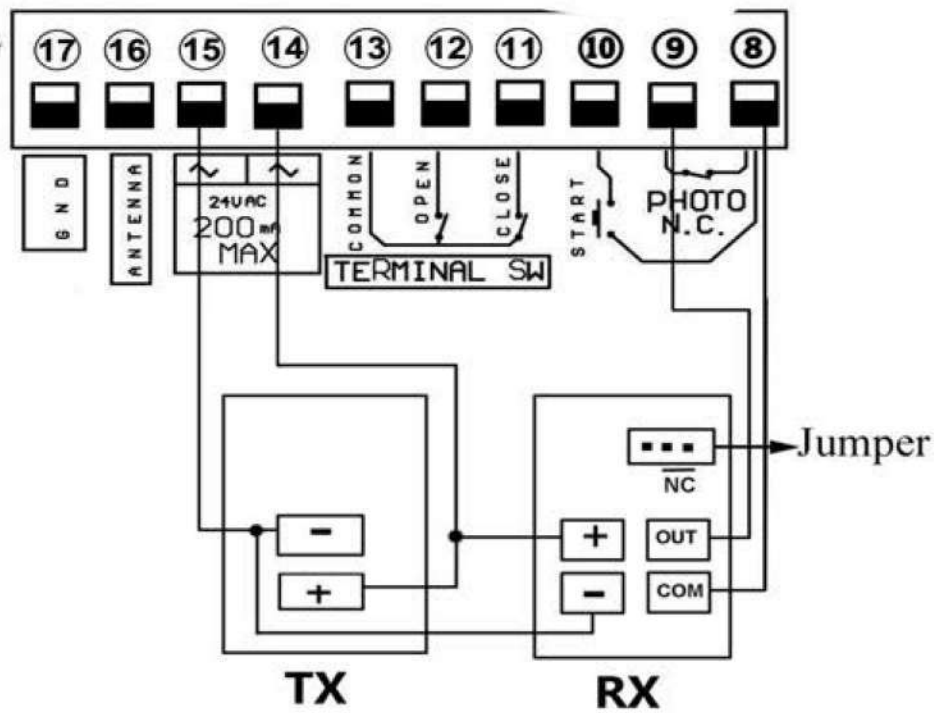

Fig 10

Firstly ,please find a little wire between terminal ⑧ and ⑨, and remove it.

Then, connect terminal ⑧ to the “COM “of photocell RX.

connect terminal ⑨ to the “OUT “of photocell RX.

Terminal ⑭ and ⑮ is supplying power for external device.

So, connect terminal ⑭ to the “+ “of photocell RX and TX.

connect terminal ⑮ to the “- “of photocell RX and TX.

Please note:220VAC sliding gate control board is designed to connect NC model of photocell, So please keep the jumper on the NC ,as picture Fig 10 shows!

6.5.Connect to open device. (Please see Fig 11)

When you don't want to use the remote control to control the gate . Terminal ⑩ is for you connect some external device , such push button, wired keypad, receiver etc.

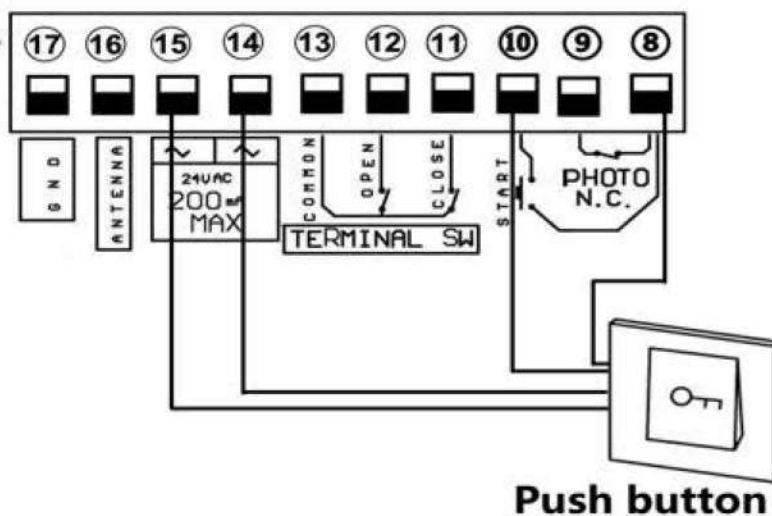

Fig 11

Example for push button;

Terminal ⑧ and ⑩ connect to push button. Terminal 14 and 15 to supply power for push button

7. Function Testing

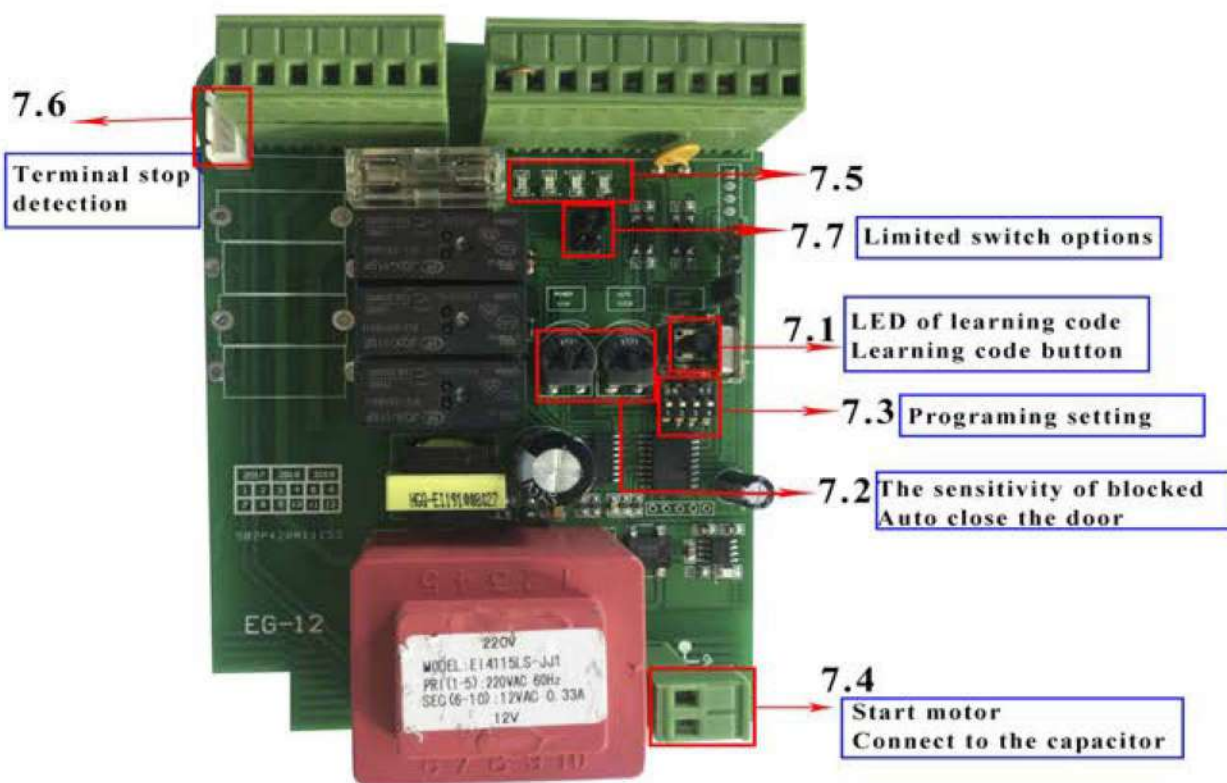

Fig 12

The following functions refer to the picture Fig 12.

7.1 Learn remote control code:

- A. Control panel can memory more than 20 pcs remote control
- B. Press board "AUTO LEARN" button,LED -D5 will lighting for 10 seconds.during this time,we just press the button of remote control.its code will learning and went in.if receiver the code,LED-D5 will go off and motor will start.
- C. If we not press any buttons, LED-D5 will go off after 10 seconds,and receiver will automatic quit learning functions.
- D. Press and hold the button 6 seconds,LED-D5 will flashes ,and then release the button,all the code will be cleared that has been memorized in control board,

7.2 Blocked detection:

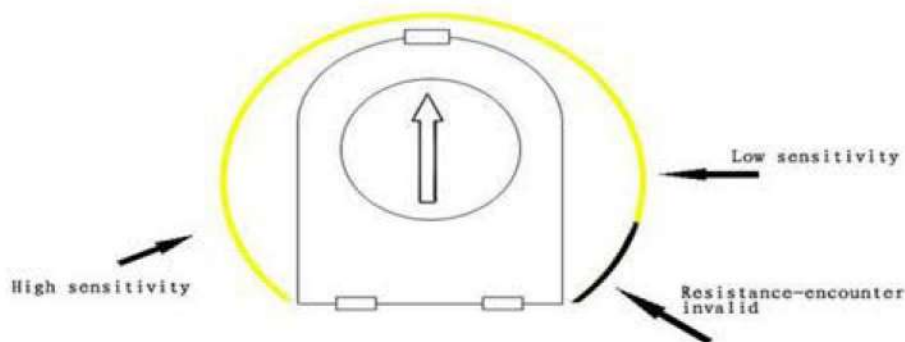

Fig 13

As picture show,we can rotate "POWER STOP "that parts.so we can adjust the sensitivity of blocked.

A. High sensitivity : when the motor is rotation,will meet some minor resistance,then control board will send a signal to let motor stop rotating.

B. Low sensitivity : when the motor is rotation,will meet greater resistance,then control board will send a signal to let motor stop rotating.

Note:when motor is rotation .If LED-D5 flashes,that show system is working now .

C. As picture show , when pointer rotate to black part ,the control panel will quit this system,and when the motor is working ,LED-D5 will not lighting .

7.3 Auto close the door :

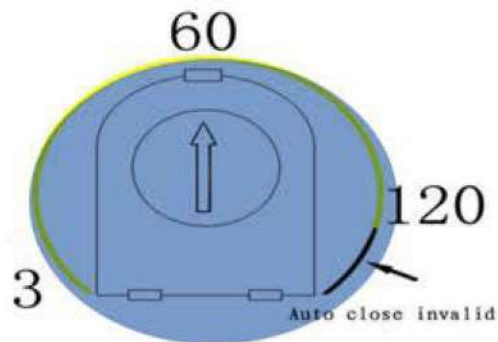

Fig 14

A. When the door is open (as long as there is open),we rotate the pointer to yellow part.the control panel will control the motor to auto close the door,this time can be adjusted in 3 seconds to 120 seconds

B. As picture show,we rotate the pointer to black area.control panel will automatically exits the closed system.

7.4 programming setting:

A. Dial-up 1→off: when motor is working, lamps will always lighting.and motor will stop and after 1 minutes the lamp is off .

Dial-up 1→on: As long as the motor is working,lamp will flashes.the motor is stop and light is off.

B. Dial-up 2→off: Motor control(Including the use of control and short start),motor working as follows

open→stop→close→stop→open……

Dial-up 2 → on: Motor control(Including the use of control and short start),motor working as follows

open→stop→close→stop, then automatic open the door ……

C. Dial-up 3→off: when the system is closed state ,there are obstacles to the infrared sensors,the motor will stop it and automatically open the door.

Dial-up 3 → on: when the system is closed state ,there are obstacles to the infrared sensors,the motor will stop it.

d. Dial-up 4→off: the resistance encounter is set for high sensitivity.

Dial-up 4→on: the resistance encounter is set for a lower sensitivity.

NOTE: In dial up 4, 'on' position, can let you have more choices for the motor position.

7.5 Motor Start Capacitors:

Capacitors are connected with control board before use motor, please confirmed the interface of capacitors is secure. Please see picture Fig 12..

7.6 Led Indicator:

D1: The infrared sensors output signal instructions

LED ON: Infrared sensors detection, there is no obstacle.

LED OFF: Infrared sensors detection, if there have obstacle when closed the door, the motor will stop working.

D2:

LED ON: We use a conductor make the START this terminal connected with the right of second terminal. the lamp will lighting it. This will realize same function (use the remote control just press one time)

LED OFF: show that no operation.

D3: Limit switch of closing the door

LED ON: The door is not completely closed

LED OFF: The door has been completely closed

D4: Limit switch of opening the door.

LED ON: The door is not completely opened

LED OFF: The door is completely opened

7.7 Terminal stop detection interface:

Terminal stop detection have 2 type, one is open the door, another is close the door. If normal working. 2 pointer will connect to two positions, when in right position, will break it.

Our products has set it and connected it before send to our customers.

7.8 Limited switch options (K1):

Limit switch is used to switch terminal stop detection interface, that direction of open and close the door

Preparation and testing :

Separating clutch, and then use hand push the door, let the door to sliding journey, and check the door is flexible or not and check racks happen stop phenomenon or not? If have, please readjust motor position or racks position. until the door can move flexible.

After installation of sliding gate opener system, please confirmed the direction of open and close the door push the door to a sliding door machine, is located near the center of the door. then close the clutch. and check electrical lines, to make sure all lines are have connected good. (according to connected electrical diagram 8 to connect it) . Finally, connected the power, and use remote control to control and move the gate, then trigger an infrared sensors. the gate will stop . show that door action is closed. Or, will delay closing the door, and time will shorter. Use remote control to control and move the door several seconds, then closed . and waiting for door can automatic move. if not. use the remote control to control and move the door several seconds again. and then waiting for door can automatic move. if can automatic move, show this action is closed the door. if closing direction do not tally with the actual direction, the will show that remote control make the motor stop and please disconnect the power. Please change the motor and control panel connection, means change OPEN and